

Social Security Administration



Section 508
Accessibility of Electronic
and Information Technology
for People with Disabilities

www.socialsecurity.gov

Guide to Applying Section 508 Standards

Table of Contents

Introduction	ii
<u>Subpart B - Technical Standards</u>	
Software Applications and Operating Systems (1194.21)	1
Web Information and Applications (1194.22)	28
Telecommunications 1194.23).....	56
Video and Multimedia (1194.24).....	70
Self-Contained, Closed Products 1194.25)	74
Desktop and Portable Computers (1194.26).....	89
<u>Subpart C - Functional Performance Criteria</u>	
Functional Recommended Evaluation Criteria (1194.31).....	93
<u>Subpart D - Information Documentation and Support</u>	
Information Documentation and Support (1194.41)	99
SSA's Additional Accessibility Requirements	i
Appendix A: Keystrokes	v

Section 508

SSA Requirements and Testing Guidelines

Introduction

The purpose of this document is to give vendors a significant and meaningful example of the features which SSA tests for in evaluating products for Section 508 compliance. This document should be used as a guideline to aid vendors in writing and completing the Voluntary Product Evaluation Templates (VPAT) and in evaluating the Section 508 compliance of their products as measured by SSA. This document should also be used as a guide for vendors to be able to determine Electronic Information Technology (EIT) Accessibility Requirements. Please refer to: [Social Security Administration Acquisitions and Grants - Section 508 Information](#)

This document contains:

- The official language for each Section 508 standard
- SSA's plain English interpretation of *most* standards
- Specific requirements describing the actual characteristics which SSA requires for determining compliance with each standard
- The Assistive Technology (AT) pertinent to each requirement
- The Testing methods, and recommended evaluation criteria SSA uses to evaluate products to determine requirement satisfaction

This document also includes SSA's Accessibility Requirements, which are used to validate compatibility in SSA's technical environment for disabled users. The current software versions of the AT used at SSA are defined, along with directions on how to obtain temporary licenses for these products (see SSA's Accessibility Requirements).

Additional Information is located at:

<http://www.section508.gov>

<http://www.accessibilityforum.org>

<http://www.access-board.gov/508.htm>

Software Applications and Operating Systems

General Rule

All testing of a software application or operating system will involve the exclusive use of either the keyboard or voice input. Since the mouse will **not** be used, the first criterion for judging the accessibility will be the ability of a user to use either keyboard or voice input to navigate to all elements on a screen. The general guideline for Section 508, followed throughout this document, is contained in Section 1194.21; that guideline pertains to both Federal employees and members of the public who may have disabilities; specifically, people with disabilities must have access to, and use of, information and data that is comparable to individuals that do not have disabilities. Access to the same or equivalent information must reflect a similar amount of time and effort by non-disabled individuals as that of disabled persons.

All testing will utilize the following Assistive Technologies:

- JAWS and Braille displays (Braille is a function of the screen reading software and must track navigation throughout an application.)
- MAGic
- Dragon Naturally Speaking

Any documentation provided with the software application or operating system shall be readable to Assistive Technology (AT) users. This includes providing meaningful text descriptions for all image elements (i.e. graphics, screen shots, diagrams, etc.) whether it is in Word, PDF, PowerPoint, or any other format. Additionally, all image elements must be readable with screen magnifiers or have an equivalent text description.

Evaluation Criteria

There are three classifications in which an application will be characterized, based on their evaluation performance:

- Critical – Cannot use the keyboard to attain focus on essential screen elements
 - Significant – Can use the keyboard but result is access that is not comparable to a mouse user resulting in significant loss of efficiency and/or productivity
 - Non-critical – Keyboard usage is laborious but usable
-

Section 1194.21.a

Standard 1194.21.a When software is designed to run on a system that has a keyboard, product functions shall be executable from a keyboard where the function itself or the result of performing a function can be discerned textually.

SSA Interpretation AT users are able to navigate using the keyboard or keyboard voice commands in a comparable manner to using the mouse.

Requirement (a.1) Hotkeys must be assigned to commonly¹ used control elements or notebook tabs to provide comparable mouse access. Tabbing which results in excessive² keystrokes to activate an element is considered non-compliant.

<i>Supported By</i>	JAWS
	MAGic
	Dragon ³
<i>Recommended Evaluation Criteria</i>	3 or less keystrokes or alternative navigation
<i>Testing Method</i>	Use keyboard or voice to navigate through the text and controls. Ensure 3 keystroke maximum; identify JAWS/MAGic/Dragon alternatives.

Requirement (a.2) Hotkeys must be assigned to links used repeatedly on more than one screen or identical links used as templates for multiple applications.

<i>Supported By</i>	JAWS
	MAGic
	Dragon ⁴
<i>Recommended Evaluation Criteria</i>	Repeatedly used links or template initiated links must have hotkeys.
<i>Testing Method</i>	Use the keyboard hotkeys to select links.

Continued on next page

¹ Commonly is defined as keystrokes needed for use outside of the tab order

² Excessive is defined as more than 3 keystrokes

³ Not a necessity if alternatives provided

⁴ Not a necessity if alternatives provided

Section 1194.21.a, Continued

Requirement (a.3) **Tab indices must be assigned to significant⁵ text information, directional cues, and error text information, or a comparable access method must be attained.**

<i>Supported By</i>	JAWS
	MAGic
<i>Recommended Evaluation Criteria</i>	All information necessary to complete a form or application must retain focus so that the information is seen or spoken.
<i>Testing Method</i>	<ul style="list-style-type: none"> • Tab through text areas to see static text areas OR • Listen to focus on static text areas

Requirement (a.4) **There must be a logical tab order. Generally left to right, top to bottom. There are cases where the tab order is application dependent. The requirement, therefore, is to have a tab order that makes sense to the user in accomplishing the task.**

<i>Supported By</i>	JAWS
	MAGic
	Dragon
<i>Recommended Evaluation Criteria</i>	The tab order, at a minimum, must progress from left to right and top to bottom. Application specific functionality must produce tab orders consistent with the flow of the application.
<i>Testing Method</i>	<ul style="list-style-type: none"> • Tab through the application to identify the tab order • Note any inconsistencies with left to right and top to bottom order • Note any instances of tab order that results to extra keystrokes that could be eliminated by improving the tab order • Tab through text areas to see or hear focus on static text areas

Continued on next page

⁵ “Significant” is defined as information that is absolutely necessary in order to productively and accurately fill out information on a form.

Section 1194.21.a, Continued

Requirement (a.5) **When frames are used there must be a navigational capability to move with the keyboard from frame to frame and/or control to control. Scrolling within a frame must be achievable through keyboard/voice command.**

<i>Supported By</i>	JAWS
	MAGic
	Dragon
<i>Recommended Evaluation Criteria</i>	CTRL + Tab or F6 must move focus from frame to frame. Tabbing from the last control in a frame must take you to the first element in the next frame. Scrolling within a frame must be achievable through keyboard or voice.
<i>Testing Method</i>	Press CTRL + Tab, F6 or the JAWS "M" command to between frames. Voice input should say the hotkey or "next frame". Scrolling will similarly be accomplished by using arrow keys or scrolling commands.

Requirement (a.6) **Navigation to screen elements with the keyboard/voice must be available in a comparable manner to a mouse.**

<i>Supported By</i>	JAWS
	MAGic
	Dragon
<i>Recommended Evaluation Criteria</i>	Keystroke/voice navigation must be within 3 keystrokes of a mouse user.
<i>Testing Method</i>	By using keyboard/voice navigation, users should not take more than 3 keystrokes to get to elements outside of the normal tab order.

Requirement (a.7) **Buttons must be accessible through voice commands; screen text cannot differ from button title attributes.**

<i>Supported By</i>	JAWS
	MAGic
	Dragon
<i>Recommended Evaluation Criteria</i>	Voice input users must be able to use speech to invoke a button based on the visible screen text.
<i>Testing Method</i>	Use voice input commands to select a button. If unselected, check whether any alt text matches the screen text.

Continued on next page

Section 1194.21.a, Continued

Requirement (a.8) **Added keystrokes must not conflict with browser keystrokes.**

<i>Supported By</i>	JAWS
	MAGic
	Dragon
<i>Recommended Evaluation Criteria</i>	Hotkeys must not conflict with the browser; hotkeys include the following for Internet Explorer (IE): <ul style="list-style-type: none"> • ALT + D • F • E • A • T • H
<i>Testing Method</i>	Use the ALT key plus any application assigned hotkeys to see where the action focuses. If neither the browser hotkey nor the assigned application hotkey is available, then the test fails.

Requirement (a.9) **Browser reserved words, like but not limited to Help, Favorites, and View, if used within the application must have a modifier word providing voice input users a unique command.**

<i>Supported By</i>	Dragon
<i>Recommended Evaluation Criteria</i>	Application developed keywords must not conflict with browser reserved words.
<i>Testing Method</i>	Use voice commands to test developed keywords.

Requirement (a.10) **The keyboard must be used to open list boxes, open and close tree structures, and navigate to the next logical item in proper order⁶.**

<i>Supported By</i>	JAWS
	MAGic
	Dragon
<i>Recommended Evaluation Criteria</i>	Standard windows-based keystrokes must be used for consistency to navigating standard controls.
<i>Testing Method</i>	Use ALT + DownArrow or F4 to open list boxes; plus key, space bar or an equivalent opens tree structures; arrow keys or tabs navigate

Continued on next page

⁶ See Appendix A for keyboard usage requirements

Section 1194.21.a, Continued

Requirement (a.11) **Navigation to radio buttons using arrow keys, items in a combo box, list views, or check boxes must not automatically select the item and/or change focus.**

<i>Supported By</i>	JAWS
	MAGic
	Dragon
<i>Recommended Evaluation Criteria</i>	OnChange events or equivalents must not act as automatic selectors in controls, thus preventing the user from changing a selection
<i>Testing Method</i>	<ul style="list-style-type: none"> • Arrow keys or tab keys should navigate in the specified controls. • Determine whether all items can be selected, whether it is a list box, radio button, or check box without auto-selection

Requirement (a.12) **When focus changes visually to a new frame/pane or a logical place on the screen, a keystroke must be available to move focus if a well-defined visual focus does not occur.**

<i>Supported By</i>	JAWS
	MAGic
	Dragon
<i>Recommended Evaluation Criteria</i>	Have single standard keystroke capability to move to frames or panes on a screen.
<i>Testing Method</i>	<ul style="list-style-type: none"> • CTRL + Tab or F6 are standard windows keystrokes to move forward to frames and panes. • Shift plus CTRL + TAB or Shift + F6 normally move backward to frames and panes.

Continued on next page

Section 1194.21.a, Continued

**Requirement
(a.13)**

When embedded links are within sentences or paragraphs, the link must stand on its own to be meaningful *and* must have a title attribute that is meaningful within the context of the sentence.

<i>Supported By</i>	JAWS
	MAGic
<i>Recommended Evaluation Criteria</i>	Embedded links must be meaningful to screen reader users and screen magnification users. A keyboard user should be able to expose alt text or tool tip using keyboard navigation to the link.
<i>Testing Method</i>	<ul style="list-style-type: none">• Screen reader users must hear the link as incorporating the meaning of the sentence that it is embedded in.• Tab indices could be used before and after the link for clarification. If tab indices are not used, the link's tool tip must be exposed with the keyboard and JavaScript examples can be provided.

Section 1194.21.b

Standard 1194.21.b Applications shall not disrupt or disable activated features of other products that are identified as accessibility features, where those features are developed and documented according to industry standards. Applications also shall not disrupt or disable activated features of any operating system that are identified as accessibility features where the application programming interface for those accessibility features has been documented by the manufacturer of the operating system and is available to the product developer.

SSA Interpretation AT users shall be able to use all aspects of an application regardless of any disabling techniques used within it. Examples include, but are not limited to, removing the tool bar and/or menu bar, creating keyboard conflicts, and creating the inability to change colors, fonts, or font sizes.

Requirement (b.1) Menu bars and toolbars cannot be removed unless equivalent functionality is provided as an alternative.

<i>Supported By</i>	JAWS
	MAGic
<i>Recommended Evaluation Criteria</i>	Menu bars must be present or contain alternatives for Accessibility Options or View options.
<i>Testing Method</i>	<ul style="list-style-type: none"> Ignore colors, fonts and font sizes from the browser. Size the text from small to large through the browser. Be able to change colors and fonts through the browser.

Requirement (b.2) Any developer assigned hotkeys must not conflict with browser hotkeys.

<i>Supported By</i>	JAWS
	MAGic
<i>Recommended Evaluation Criteria</i>	There must be no conflict with hotkeys.
<i>Testing Method</i>	All hotkeys, whether browser based or application developed, must be accessible and operable through the keyboard.

Continued on next page

Section 1194.21.b, Continued

**Requirement
(b.3)**

The ability to use Windows selectable colors must not be disabled by the application.

<i>Supported By</i>	MAGic
<i>Recommended Evaluation Criteria</i>	Select high contrast colors for foreground and background colors (ex. white/black).
<i>Testing Method</i>	<ul style="list-style-type: none">• Select "ignore colors" from the Accessibility options• Visually identify color changes• Go to Display Options, appearance and change the colors to see if screens change

Section 1194.21.c

Standard 1194.21.c **A well-defined on-screen indication of the current focus shall be provided that moves among interactive interface elements as the input focus changes. The focus shall be programmatically exposed so that Assistive Technology can track focus and focus changes.**

SSA Interpretation AT users shall be able to use the keyboard or voice commands to move to logical points of focus in order to attain focus on selected items.

Requirement (c.1) **When selected, interface elements (i.e. button/link) must move focus to the resultant action of that element (e.g. selecting a folder moves focus to Open File dialog box).**

<i>Supported By</i>	JAWS
	MAGic
	Dragon
<i>Recommended Evaluation Criteria</i>	Focus must move to the result of the action selected.
<i>Testing Method</i>	<ul style="list-style-type: none"> • Once a control is selected, see if there is a well-defined visual focus present • If not, tab once to see refocusing. • Any other destination other than the intended focus is failing.

Requirement (c.2) **When a Search is executed, the focus must move to the results of the search, i.e., how many hits or no hits. The next tab must move to the first successful “hit” or back to Search files if no hits are found.**

<i>Supported By</i>	JAWS
	MAGic
	Dragon
<i>Recommended Evaluation Criteria</i>	After a search is executed, the focus must go to the first hit link or a message confirming how many/no hits were attained.
<i>Testing Method</i>	<ul style="list-style-type: none"> • Select the Search button and see where it focuses • Press tab once to see if the focus refocuses on the results.

Continued on next page

Section 1194.21.c, Continued

Requirement (c.3) In Help utilities where frames are used, when keywords or content subjects are selected, the focus must move to the contents frame/pane.

<i>Supported By</i>	JAWS
	MAGic
	Dragon
<i>Recommended Evaluation Criteria</i>	A well-defined visual focus must move from the current frame to the content in the selected frame.
<i>Testing Method</i>	<ul style="list-style-type: none"> • Select a help topic and then tab • Focus should be in the frame of the item selected and not remaining in the frame of topics.

Requirement (c.4) When frames are used there must be a logical navigational capability to move using keyboard/voice commands from frame to frame and/or control to control.

<i>Supported By</i>	JAWS
	MAGic
	Dragon
<i>Recommended Evaluation Criteria</i>	The standard windows keystrokes for frame navigation or application developed keystroke must move the focus from frame to frame with a well-defined focus evident.
<i>Testing Method</i>	<ul style="list-style-type: none"> • Use CTRL + Tab or F6 to move the focus from frame to frame • Test the movement to a new frame by noticing focus around the frame and/or press tab to see where the new focus is • Shift + CTRL + Tab or Shift + F6 will move back through the frames • The JAWS keystroke INS + F9 will show the list of frames • The JAWS quick key, M or Shift + M, will navigate to/from frames

Continued on next page

Section 1194.21.c, Continued

Requirement (c.5)

When hidden frames are used for work areas or other non-navigational purposes, the display for these frames must be disabled and height and width set to zero. This prevents non-visual focus shifting to hidden frames, causing unnecessary and unknown tab stops.

<i>Supported By</i>	JAWS
	MAGic
	Dragon
<i>Recommended Evaluation Criteria</i>	Screen readers should neither navigate nor speak hidden frames.
<i>Testing Method</i>	<ul style="list-style-type: none"> • Use the JAWS command, INS + F9 to display the frames • Hidden frames should not be on the list. CTRL + Tab or F6 navigates to frames. All usable frames should have focus • If the keystroke produces no focus then a defect occurs. The JAWS quick key, M, can be used to test navigation to frames

Requirement (c.6)

Focus to usable parts of an application/screen must be attained using keyboard/voice commands.

<i>Supported By</i>	JAWS
	MAGic
	Dragon
<i>Recommended Evaluation Criteria</i>	Keystrokes or voice input must be available to navigate to any portion of the screen that provides information necessary for an action.
<i>Testing Method</i>	Use keystrokes or voice to attain focus on all informational and input areas of a screen.

Continued on next page

Section 1194.21.c, Continued

Requirement (c.7) **Focus cannot be changed in two places concurrently. That is, selecting an action for a checkbox, for example, cannot change the status of other elements on screen.**

<i>Supported By</i>	JAWS
	MAGic
<i>Recommended Evaluation Criteria</i>	Focus can only be produced by a single action. Multiple simultaneous focal points must not be used.
<i>Testing Method</i>	Test to see whether highlights and or focal points are shown in multiple areas of a screen.

Requirement (c.8) **When there are links that move focus to the bottom of a page, there is usually a link that returns the user to the topic at the top of the page. Focus must return to the link the user selected, not just the top of the page. Also, in the event of multiple links, the users should be able to skip back to where they left off, rather than scrolling through.**

<i>Supported By</i>	JAWS
	MAGic
<i>Recommended Evaluation Criteria</i>	Focus must return to the original selection point in returning to a list of links.
<i>Testing Method</i>	See Certificates of Coverage

Section 1194.21.d

Standard 1194.21.d **Sufficient information about a user interface element including the identity, operation and state of the element shall be available to Assistive Technology. When an image represents a program element, the information conveyed by the image must also be available in text.**

SSA Interpretation AT shall be aware of all controls and functions of applications including but not limited to Client/Server, Mainframe, HTML, Java or Flash.

Requirement (d.1) **Navigation to controls must result in appropriate speaking of labels, data and cues.**

<i>Supported By</i>	JAWS
<i>Recommended Evaluation Criteria</i>	All data must be understandable in order to fill in appropriate responses to input areas.
<i>Testing Method</i>	<ul style="list-style-type: none"> • Navigate to controls. • Test whether JAWS speaks the necessary information to accurately supply the required response.

Requirement (d.2) **Navigation to controls must result in a well-defined visual focus.**

<i>Supported By</i>	JAWS
	MAGic
	Dragon
<i>Recommended Evaluation Criteria</i>	There must be a visible cursor, border, highlight, or some other indication to show the focus is on the screen.
<i>Testing Method</i>	Once a control is selected... <ul style="list-style-type: none"> • See if there is a well-defined visual focus present • If not, tab once to see refocusing. Any other destination other than the intended focus is failing.

Continued on next page

Section 1194.21.d, Continued

**Requirement
(d.3)**

Navigation to controls must track with screen magnifiers.

<i>Supported By</i>	MAGic
<i>Recommended Evaluation Criteria</i>	Screen magnifiers must track to the focal point when moving to controls or others areas of focus.
<i>Testing Method</i>	<ul style="list-style-type: none">• Tab to a control with the screen magnifier set to 6-8X magnification• Test to see whether focus moves to the new control and is positioned properly for reading.

**Requirement
(d.4)**

Interface elements must be exposed to voice recognition technology so users can access all controls.

<i>Supported By</i>	Dragon
<i>Recommended Evaluation Criteria</i>	Using voice input, navigate to controls
<i>Testing Method</i>	Use Dragon Naturally speaking to move to and select all controls present on a screen.

Section 1194.21.e

**Standard
1194.21.e**

When bitmap images are used to identify controls, status indicators, or other programmatic elements, the meaning assigned to those images shall be consistent throughout an application's performance.

**SSA
Interpretation**

AT shall be able to access these bitmap images.

Note!! There are no specific requirements at this time.

Section 1194.21.f

Standard 1194.21.f **Textual information shall be provided through operating system functions for displaying text. The minimum information that shall be made available is text content, text input caret location, and text attributes.**

SSA Interpretation AT shall be able to identify text elements so that it speaks or focuses/tracks accordingly.

Requirement (f.1) **Screen readers should speak all significant text displayed**

<i>Supported By</i>	JAWS
<i>Recommended Evaluation Criteria</i>	Navigate through an application and ensure the screen reader speaks all textual information necessary to complete an application or understand a screen of text.
<i>Testing Method</i>	Tab through web pages and listen to all spoken text to ensure that all necessary information is provided.

Requirement (f.2) **AT must be able to attain focus to textual elements in order to speak or gain focus.**

<i>Supported By</i>	JAWS
	MAGic
<i>Recommended Evaluation Criteria</i>	Speaking textual elements and tracking to text must be made available to the assistive technologies.
<i>Testing Method</i>	Tab indices must be assigned to textual elements and thus be “tabbable” when navigating through screens.

Section 1194.21.g

Standard 1194.21.g **Applications shall not override user selected contrast and color selections and other individual display attributes.**

SSA Interpretation AT users must have the ability to select contrast and color selections in order to individualize visual settings that best meet their needs.

Requirement (g.1) **For browsers, users must be able to check “ignore colors” under Internet Options\Accessibility. This is followed by changing colors from the Windows Display Settings.**

<i>Supported By</i>	MAGic
<i>Recommended Evaluation Criteria</i>	Users must be able to change colors on the screen to high contrast or any other color combination desired.
<i>Testing Method</i>	<ul style="list-style-type: none"> • Check “ignore colors” under Tools\Accessibility • Notice whether the web page changes • If not, then the colors are hard coded • If colors change... <ul style="list-style-type: none"> ➤ Go to Display options under the OS ➤ Change the appearance to high contrast or other color combinations to identify changeable elements.

Requirement (g.2) **For client, server, or mainframe applications, users must be able to change colors from the Windows Display Settings.**

<i>Supported By</i>	MAGic
<i>Recommended Evaluation Criteria</i>	Users must be able to change colors on the screen to high contrast or any other color combination desired.
<i>Testing Method</i>	Go to the display options under the OS and change the appearance to high contrast or other color combinations to see which elements can be changed.

Section 1194.21.h

Standard 1194.21.h **When animation is displayed, the information shall be displayable in at least one non-animated presentation mode at the option of the user.**

SSA Interpretation AT users shall be able to access animated presentations.

Requirement (h.1) **Screen readers must be able to speak any animation or describe the animation that is displayed.**

<i>Supported By</i>	JAWS
<i>Recommended Evaluation Criteria</i>	Screen readers must either speak or describe any animation displayed.
<i>Testing Method</i>	Navigate to/through a screen with animation. All content of the animation must be accessible to the screen reader.

Requirement (h.2) **Animation speech must not conflict with the screen reader's speech engine.**

<i>Supported By</i>	JAWS
<i>Recommended Evaluation Criteria</i>	If inherent speech is provided by the animation or application and not made available to the screen reader, all functionality of a screen reader, like "repeat what was spoken", must be supplied.
<i>Testing Method</i>	Navigate to a screen with animation. Use a screen reader to listen to the page. If the screen reader is not speaking properly, listen for the animation to speak. Ensure that either way, the animation is meaningful.

Requirement (h.3) **AT users should have the ability to change text size and colors of any text associated with animations or be presented textually in a non-animated manner.**

<i>Supported By</i>	MAGic
<i>Recommended Evaluation Criteria</i>	Change text size and color including foreground and background animations. Addable text must describe animation and be customizable for color/font size.
<i>Testing Method</i>	Use the browser's view menu to change the font size and display colors to change foreground and background colors.

Continued on next page

Section 1194.21.h, Continued

Requirement (h.4) AT users must be able to readily stop animation and be able to access a non-animated mode.

<i>Supported By</i>	JAWS
	MAGic
	Dragon
<i>Recommended Evaluation Criteria</i>	There must be a keystroke, button or control to turn off the animation. When this is invoked an alternative text description must be supplied.
<i>Testing Method</i>	Use the keyboard or voice to stop animation and present information in an alternative format.

Requirement (h.5) If speech accompanies an animation, there must be a synchronized addition of text that is functionally equivalent to the displayed animation for users who are deaf/hard of hearing.

<i>Supported By</i>	JAWS Deaf/Hard of Hearing
<i>Recommended Evaluation Criteria</i>	Speech and text must appear on the same screen and be synchronized.
<i>Testing Method</i>	Test to see whether any speech associated with an animation also has text that is directly associated with the animation on the screen.

Requirement (h.6) Voice Recognition users must have a means to control the animation

<i>Supported By</i>	Dragon
<i>Recommended Evaluation Criteria</i>	The use of voice input must be available to control the animation by stopping it or slowing it down.
<i>Testing Method</i>	Use voice input only to stop animation, slow it down, control speaking or any other characteristics inherent within the animation.

Section 1194.21.i

Standard 1194.21.i **Color coding shall not be used as the only means of conveying information, indicating an action, prompting a response, or distinguishing a visual element.**

SSA Interpretation AT users shall be able to understand any color indication for conveying information.

Requirement (i.1) **Users of screen readers must have access to alternative text that indicates a condition of color.**

<i>Supported By</i>	JAWS
<i>Recommended Evaluation Criteria</i>	Any indication of color as a means of conveying information must contain a text alternative.
<i>Testing Method</i>	Test to see whether any indicators of color have text alternatives.

Requirement (i.2) **Low vision users who also use screen readers must be able to understand the selection of the color names through the screen reader by using the keyboard to navigate to them.**

<i>Supported By</i>	JAWS
<i>Recommended Evaluation Criteria</i>	Any indication of color as a means of conveying information must contain a text alternative.
<i>Testing Method</i>	Change colors to high contrast to see if meaning is still available without color.

Section 1194.21.j

Standard 1194.21.j When a product permits a user to adjust color and contrast settings, a variety of color selections capable of producing a range of contrast levels shall be provided.

Requirement (j.1) Low vision users who also use screen readers must be able to understand the selection of the color names through the screen reader by using the keyboard to navigate to them.

<i>Supported By</i>	JAWS
	MAGic
<i>Recommended Evaluation Criteria</i>	Any color selection must be keyboard navigable for selection purposes.
<i>Testing Method</i>	Use the keyboard to navigate through color palettes or other types of pick lists.

Requirement (j.2) All colors depicted for color choices must have accompanying text descriptions.

<i>Supported By</i>	JAWS
	MAGic
<i>Recommended Evaluation Criteria</i>	Any color palettes or other means of selecting colors must have alt text relating the color image to indicated the shade of color.
<i>Testing Method</i>	Use the screen reader to access a color palette or list of colors and listen for the text equivalent.

Section 1194.21.k

Standard 1194.21.k **Software shall not use flashing or blinking text, objects, or other elements having a flash or blink frequency greater than 2 Hz and lower than 55 Hz.**

SSA Interpretation AT users must not be affected by software that uses flashing or blinking text. Users must have the ability to disable any flashing/ blinking text or animation.

Requirement (k.1) **Any on-screen flashing/blinking must have the ability to be disabled.**

<i>Supported By</i>	JAWS
	MAGic
	Dragon
<i>Recommended Evaluation Criteria</i>	A control or setting must be provided to adjust or stop flashing/blinking.
<i>Testing Method</i>	Use the keyboard to adjust or stop flashing/blinking elements on a screen.

Requirement (k.2) **Any flashing/blinking that conveys meaning must have an accessible text alternative.**

<i>Supported By</i>	JAWS
	MAGic
	Dragon
<i>Recommended Evaluation Criteria</i>	When stopped or adjusted the flashing/blinking must have a text description of the action.
<i>Testing Method</i>	Use the keyboard and screen reader to test information being conveyed by flashing/blinking elements.

Section 1194.21.I

Standard 1194.21.I **When electronic forms are used, the form shall allow people using Assistive Technology to access the information, field elements, and functionality required for completion and submission of the form, including all directions and cues.**

SSA Interpretation AT users must have access to all controls, labels, directions, and cues for an electronic form. Electronic forms are defined as “anytime a webpage or software program requests information from the user, the user is interacting with a form”.

Requirement (I.1) **Screen readers must speak all controls, labels, directions, and cues in a logical order.**

<i>Supported By</i>	JAWS
<i>Recommended Evaluation Criteria</i>	All direction, cues, labels, and instructions must be spoken in order to fill out a field properly.
<i>Testing Method</i>	<ul style="list-style-type: none">• Navigate through an application• Test to see whether all information is spoken in order to fill out a form properly

Requirement (I.2) **Keyboard users must get focus to all controls, directions, and cues.**

<i>Supported By</i>	MAGic
<i>Recommended Evaluation Criteria</i>	Focus must be visible on all controls, directions and cues.
<i>Testing Method</i>	<ul style="list-style-type: none">• Navigate through an application• Identify well-defined visual focus on directions, controls, and cues.

Requirement (I.3) **Error handling is added to this section. Errors can be handled by the use of pop-ups, “red balls” or any other means. Errors can also be displayed after inputting a field or submitting a page. Access to errors must be keyboard accessible and comparable to a mouse user.**

Continued on next page

Section 1194.21.I, Continued

Requirement (I.3) (continued)

<i>Supported By</i>	JAWS
	MAGic
<i>Recommended Evaluation Criteria</i>	All error information must receive focus, and navigation to errors must be keyboard-able and productive with a minimum of keystrokes.
<i>Testing Method</i>	If pop-up errors are displayed, they must receive focus and speak. Other indicators of errors must have a well-defined visual focus, speak the error message and provide a means of navigating to successive errors in a productive keyboard manner.

Requirement (I.4)

Voice Recognition users must have access by voice command to all Menus, Toolbars, and Field Elements.

<i>Supported By</i>	Dragon
<i>Recommended Evaluation Criteria</i>	Using voice, users must be able to control all elements of the screen including menus, toolbars and any other navigable element.
<i>Testing Method</i>	Use voice to gain access to all elements of a screen needed to complete the information needed on a screen.

For errors displayed through a pop-up, there are specific requirements:

Requirement (I.5)

The information within the pop-up should speak immediately through a screen reader.

<i>Supported By</i>	JAWS
<i>Recommended Evaluation Criteria</i>	Any pop-up message must speak immediately and completely through the screen reader
<i>Testing Method</i>	When a pop-up message appears, wait to hear what the screen reader says. If it does not speak all information present, use the JAWS command INS + B to see whether additional information is spoken or whether the information spoken can be repeated. The pop-up must have a well defined visual focus. This is apparent by the title bar being highlighted or a control having focus.

Continued on next page

Section 1194.21.I, Continued

Requirement (I.6)

The pop-up should receive focus for screen magnification software.

<i>Supported By</i>	MAGic
<i>Recommended Evaluation Criteria</i>	Any pop-up must receive automatic focus.
<i>Testing Method</i>	The pop-up must have a well defined visual focus. This is apparent by the title bar being highlighted or a control having focus.

Requirement (I.7)

Text in a pop-up should be able to be increased in size through operating system settings.

<i>Supported By</i>	MAGic
<i>Recommended Evaluation Criteria</i>	Font size and colors must be configurable through operating system functions.
<i>Testing Method</i>	<ul style="list-style-type: none"> • Use the Windows display settings to choose Appearance/Advanced. • Choose Message Box or other windows elements to change the font, font size and/or colors.

Requirement (I.8)

The screen names of any button will be at the beginning of any Alt-text if Alt-text is present.

<i>Supported By</i>	JAWS
	MAGic
	Dragon
<i>Recommended Evaluation Criteria</i>	Screen names must be the same at the start of any alt text. Voice input uses the alt text on buttons with the screen text.
<i>Testing Method</i>	Use voice to initiate a button control to see whether the action can be invoked by voice.

Continued on next page

Section 1194.21.I, Continued

For errors displayed on a page after submittal, there are specific requirements:

Requirement (I.9) A list of errors must be identified at the top of the page and receive focus. Links to each error must be displayed at the top of the page.

<i>Supported By</i>	JAWS
	MAGic
	Dragon
<i>Recommended Evaluation Criteria</i>	Errors must be displayed at the top of a page indicating the number and links to these errors or a way to get to consecutive errors with the keyboard.
<i>Testing Method</i>	Test for focus on errors at the top of the page by seeing a visual focus or hearing the number of errors. Select the first error to see if focus moves to that control. Use the JAWS or MAGic links list command to bring back the list of errors.

Requirement (I.10) Each error on the page is associated with the element in error by some indicator that is identified by speech or text.

<i>Supported By</i>	JAWS
	MAGic
<i>Recommended Evaluation Criteria</i>	Error message text must be associated with each error element. All error messages must be understandable to productively correct the error.
<i>Testing Method</i>	Visual and auditory checks will identify error messages associated with each control and understandable messages in order to correct them.

Requirement (I.11) The user must have the ability to navigate precisely to each identified error on the page and know precisely where each error is without having to navigate through an entire form.

<i>Supported By</i>	JAWS
	MAGic
<i>Recommended Evaluation Criteria</i>	Techniques must be provided to navigate directly to errors on the page within 3 keystrokes.
<i>Testing Method</i>	Navigate to successive errors on a page. Navigation must be within 3 keystrokes of moving from error to error within a field.

Section 1194.21 End

Web Information and Applications

Section 1194.22.a

Standard 1194.22.a A text equivalent for every non-text element shall be provided (e.g. via “alt”, “longdesc”, or in element content).

SSA Interpretation AT users shall be able to access all meaningful non-text elements.

Requirement (a.1) Screen readers shall be able to speak all alt text or equivalent elements.

<i>Supported By</i>	JAWS
<i>Recommended Evaluation Criteria</i>	All alt text must be meaningful and speak when accessed.
<i>Testing Method</i>	Tab through controls to ensure that they speak and are meaningful. Arrow through images to see that they speak and are meaningful.

Requirement (a.2) Keyboard and voice input users must be able to access all text equivalent alternatives for non-text elements.

<i>Supported By</i>	JAWS
	MAGic
	Dragon
<i>Recommended Evaluation Criteria</i>	All alt text or any equivalent must be exposed by the keyboard or voice input.
<i>Testing Method</i>	Navigate by keyboard to see whether alt text or tool tips are exposed by using the keyboard or voice. ASB has developed a JavaScript capability to accomplish this.

Continued on next page

Section 1194.22.a, Continued

**Requirement
(a.3)**

If textual links are not possible, then the screen name of the non-text element will be at the beginning of the alt-text tag, long description, title attribute, etc.

<i>Supported By</i>	JAWS
	MAGic
	Dragon
<i>Recommended Evaluation Criteria</i>	All text links must have alt text beginning with the screen text shown.
<i>Testing Method</i>	Use AT to expose alt text using screen readers, keyboard, or voice input.

Continued on next page

Section 1194.22.b

Standard 1194.22.b **Equivalent alternatives for any multimedia presentation shall be synchronized with the presentation.**

SSA Interpretation AT users must be able to access all multimedia presentations or alternatives.

Requirement (b.1) **Multimedia presentation must have a text alternative.**

<i>Supported By</i>	JAWS
	MAGic
<i>Recommended Evaluation Criteria</i>	Any type of multimedia presentation must have a text alternative.
<i>Testing Method</i>	Use AT to access the content of multimedia presentations.

Requirement (b.2) **Text must be sizable; background and foreground colors must be modifiable.**

<i>Supported By</i>	MAGic
<i>Recommended Evaluation Criteria</i>	Multimedia elements must be sizable and colors must be modifiable. If this is not possible, then equivalent text alternatives must be provided.
<i>Testing Method</i>	Use the Windows Display/Appearance/Advance options to size and change the colors.

Requirement (b.3) **Multimedia presentation must be able to be stopped by configuration settings or keyboard control.**

<i>Supported By</i>	JAWS
	MAGic
<i>Recommended Evaluation Criteria</i>	User preferences or keyboard access must be provided to stop or create an alternative appearance for multimedia presentation.
<i>Testing Method</i>	Use the keyboard or configuration settings to stop or create an alternative view for multimedia presentations.

Continued on next page

Section 1194.22.a, Continued

Requirement (b.4) **Sound or voice associated with presentations must have the ability to be turned off.**

<i>Supported By</i>	JAWS
<i>Recommended Evaluation Criteria</i>	Sound or voice associated with multimedia presentations must have a keystroke or configuration setting to turn it on or off.
<i>Testing Method</i>	Use the keyboard or configuration setting to turn speech and/or sounds that accompany multimedia presentations on or off.

Requirement (b.5) **Sound or voice associated with presentation must have a text equivalent and be synchronized with the presentation.**

<i>Supported By</i>	JAWS
	MAGic
	Dragon
	Deaf/Hard of Hearing
<i>Recommended Evaluation Criteria</i>	Any sound or voice must have a text equivalent and be synchronized with the presentation.
<i>Testing Method</i>	Navigate to the multimedia presentation and see whether captioning is provided with the sound or voice presentation. A separate text equivalent is not acceptable.

Requirement (b.6) **Voice input users must be able to control the presentation using voice.**

<i>Supported By</i>	Dragon
<i>Recommended Evaluation Criteria</i>	Voice input must be able to start or stop a presentation and to control any other parts of the presentations (volume, speed, etc.)
<i>Testing Method</i>	Use voice input to control all aspects of a multimedia presentation.

Section 1194.22.c

Standard 1194.22.c **Web pages shall be designed so that all information conveyed with color is also available without color, for example, from context or markup.**

SSA Interpretation Color shall not be the only means to convey information or an action.

Requirement (c.1) **Apply text equivalents to any information that is color depicted.**

<i>Supported By</i>	JAWS
	MAGic
<i>Recommended Evaluation Criteria</i>	Text equivalents must be readily apparent to any color coded screen element.
<i>Testing Method</i>	Use the keyboard to navigate through color coded elements. Any color coding must expose text elements and be spoken or keyboard accessible.

Requirement (c.2) **Do not use color as the only means of conveying information or an action.**

<i>Supported By</i>	JAWS
	MAGic
<i>Recommended Evaluation Criteria</i>	Provide alternatives to color coding.
<i>Testing Method</i>	See if there are any alternatives for color coding.

Section 1194.22.d

Standard 1194.22.d Documents shall be organized so they are readable without requiring an associated style sheet.

SSA Interpretation Style sheets shall not interfere with user-defined style sheets and users shall be able to override styles sheets with Windows settings. Content can still be read in a “logical” fashion, even if the application’s style sheet is disabled.

Requirement (d.1) Screen readers must be able to speak properly if style sheets are turned off.

<i>Supported By</i>	JAWS
<i>Recommended Evaluation Criteria</i>	Determine if screen readers speak all controls properly when style sheets are off.
<i>Testing Method</i>	Turn off style sheets using the web accessibility toolbar.

Requirement (d.2) All colors and text must be modifiable for low vision users if style sheets are turned off.

<i>Supported By</i>	JAWS
<i>Recommended Evaluation Criteria</i>	Identify if low vision users have the same capabilities with style sheets turned off in regard to text size and colors.
<i>Testing Method</i>	Turn off style sheets using the web accessibility toolbar.

Section 1194.22.e

Standard 1194.22.e	Redundant text links shall be provided for each active region of a server-side image map.
------------------------------	--

SSA Interpretation	Redundant text links shall be accessible to AT users for links of server-side image maps.
---------------------------	---

**No Case of Occurrence*

Section 1194.22.f

Standard 1194.22.f **Client-side image maps shall be provided instead of server-side image maps except where the regions cannot be defined with an available geometric shape.**

SSA Interpretation AT users should be able to access client-side image map links. It is highly recommended to avoid client-side image map links or any image based links, as it presents accessibility issues for keyboard and MAGic users.

Requirement (f.1) **Screen readers must be able to speak meaningful text alternatives.**

<i>Supported By</i>	JAWS
<i>Recommended Evaluation Criteria</i>	Any image links must have meaningful alt text.
<i>Testing Method</i>	Tab to the link and see if JAWS speaks understandable alt text links.

Requirement (f.2) **Low vision and keyboard users must be able to access text alternatives with the keyboard.**

<i>Supported By</i>	MAGic
<i>Recommended Evaluation Criteria</i>	When the link is navigated to, the alt text must be exposed. All colors and sizing must be available for this link.
<i>Testing Method</i>	<ul style="list-style-type: none"> • Tab to the image map link; the alt text should be in focus so that it is readable. • Use the view menu to size the text; it must be able to be increased. • Change the colors using “ignore colors” from the accessibility options and use “high contrast” options for the display settings; these must be modifiable.

Requirement (f.3) **Voice input users must be able to discern any alternative text that is different than screen text by using voice.**

<i>Supported By</i>	Dragon
<i>Recommended Evaluation Criteria</i>	Client-side image maps links must be selectable by voice.
<i>Testing Method</i>	Use voice to select a link. If it is not selectable, then the alt text must include the beginning screen text.

Section 1194.22.g

Standard
1194.22.g

Row and column headers shall be identified for data tables.

Requirement
(g.1)

Screen readers must be able to associate row and column headers with data elements when navigated to within a table.

<i>Supported By</i>	JAWS
<i>Recommended Evaluation Criteria</i>	All row and column headers must speak while navigating through cells in a table.
<i>Testing Method</i>	<ul style="list-style-type: none">• Use the JAWS table reading commands to speak row and column headers while navigating through a table (CTRL + ALT + Arrow Keys).• Use CTRL + ALT = NumPad 5 to speak the current cell information that has virtual cursor focus.

Requirement
(g.2)

Screen magnification users must be able to associate row and column headers with data elements.

<i>Supported By</i>	MAGic
<i>Recommended Evaluation Criteria</i>	Screen magnification users must be able to have the row and column headers exposed while navigating through a table.
<i>Testing Method</i>	<ul style="list-style-type: none">• Tab to a table. ALT Text tab indices must be supplied in order to use keyboard navigation through a table• The ALT TEXT must be exposed (JavaScript example). See RASMTAS.

Section 1194.22.h

Standard 1194.22.h **Markup shall be used to associate data cells and header cells for data tables that have two or more logical levels of row or column headers.**

SSA Interpretation Screen readers shall be able to speak all elements of tables including table with two or more logical levels of row or column headers.

Requirement (h.1) **Screen readers shall be able to associate row and column headers with data elements when navigated to within a table.**

<i>Supported By</i>	JAWS
<i>Recommended Evaluation Criteria</i>	Multi-level data table row headings and columns must be spoken by JAWS
<i>Testing Method</i>	Navigate through a table to see whether all multi-level heading are spoken. Combinations of <thead><col>, <colgroup>, and <th> elements as well as "axix", "id", "scope", and "header" attributes must be present.

Requirement (h.2) **Screen magnification users shall be able to associate row and column headers with data elements.**

<i>Supported By</i>	MAGic
<i>Recommended Evaluation Criteria</i>	Multi-level data table row headings must be accessible to MAGic users.
<i>Testing Method</i>	Navigate through a table. All multi-level column and row headers must be exposed and accessible to the screen magnifier.

Section 1194.22.i

Standard 1194.22.i **Frames shall be titles with text that facilitates frame identification and navigation.**

Requirement (i.1) **Screen readers must be able to speak all frame names in a meaningful manner.**

<i>Supported By</i>	JAWS
<i>Recommended Evaluation Criteria</i>	Frame names must be meaningful and not include frame as part of its name.
<i>Testing Method</i>	<ul style="list-style-type: none"> • Press F6, CTRL + Tab, or “M” with JAWS running to hear the frame speak. • Press INS + F9 to get a list of frames and their names.

Requirement (i.2) **Navigation to frames with a keyboard must be equivalent to navigating with a mouse.**

<i>Supported By</i>	JAWS
	MAGic
	Dragon
<i>Recommended Evaluation Criteria</i>	Frames must be navigable with a single keystroke.
<i>Testing Method</i>	Press F6, CTRL + Tab, or the JAWS quick key “M” to move from frame to frame.

Requirement (i.3) **Frames must be designed so that voice commands provide visible navigation to the frame and functionality.**

<i>Supported By</i>	Dragon
<i>Recommended Evaluation Criteria</i>	Voice input must be capable of moving from frame to frame
<i>Testing Method</i>	Use the Dragon frame command to move from frame to frame. A well-defined visual focus must be evident around the frame.

Continued on next page

Section 1194.22.i, Continued

Requirement (i.4) **Hidden frames used for storage or work areas must not be spoken or exposed to assistive technologies.**

<i>Supported By</i>	JAWS
	MAGic
<i>Recommended Evaluation Criteria</i>	Hidden frames must not be spoken, appear on a frames list, or be navigable.
<i>Testing Method</i>	Use the frames keystroke to move to frames. Hidden frames must not get focus, be spoken or appear in a JAWS frame. Hidden frames or working frames must not be spoken when screens are introduced or refreshed.

Requirement (i.5) **Excessive⁷ use of frames must not be used when unnecessary for navigation or information purposes.**

<i>Supported By</i>	JAWS
	MAGic
<i>Recommended Evaluation Criteria</i>	Tabbing controls should result in no speech or focus.
<i>Testing Method</i>	<ul style="list-style-type: none"> • Tab through an implication to see if there is loss of focus or speech. • Use CTRL + Tab, F6, or the screen reader quick key for navigating frames (JAWS uses the letter "M").

⁷ Excessive, in this instance, implies frames not used for primary navigation within an application or web page.

Section 1194.22.j

Standard 1194.22.j Pages shall be designed to avoid causing the screen to flicker with a frequency greater than 2 Hz and lower than 55Hz.

SSA Interpretation Any screen flicker that is distracting to a user must have the ability to be disabled.

Requirement (j.1) Screen flicker or screen flashing of any kind must have the ability to be disabled.

<i>Supported By</i>	MAGic
<i>Recommended Evaluation Criteria</i>	Any noticeable flicker or flashing will be intensified by screen magnifiers.
<i>Testing Method</i>	<ul style="list-style-type: none">• Turn magnification on and notice flashing of the screen.• Increase the magnification to judge distracting screen flashing.

Requirement (j.2) Any “red” flashing of elements or flicker must have the ability to be disabled or the color changed.

<i>Supported By</i>	MAGic
<i>Recommended Evaluation Criteria</i>	Any “red” flashing of elements or flicker must have the ability to be disabled or the color changed.
<i>Testing Method</i>	Use a keystroke or configuration setting to disable or change the color of red flashing/blinking elements.

Section 1194.22.k

**Standard
 1194.22.k**

A text-only page, with equivalent information or functionality, shall be provided to make a web site comply with the provision of this part, when compliance cannot be accomplished in any other way. The content of the text-only page shall be updated whenever the primary page changes.

**SSA
 Interpretation**

The text-only page provided to meet this requirement must also be designed to allow screen readers to be able to speak appropriately with equivalence to a non-text alternative. In addition, all text-only pages must have equivalent keyboard navigation, text size, and color modification capabilities with equivalence to a non-text alternative.

**Requirement
 (k.1)**

Text only pages must provide equivalent content as their graphical counterpart.

<i>Supported By</i>	JAWS
	MAGic
	Dragon
<i>Recommended Evaluation Criteria</i>	The information provided on a text only page must be equivalent to the text, images, charts, etc. on a text and graphical page.
<i>Testing Method</i>	Compare screen by screen graphical and text only pages. Images with meaning must be conveyed for text pages, all notes, instructions, tables, and error handlings must convey comparable meaning to the non-text only screen.

**Requirement
 (k.2)**

Text alternative pages must contain equivalent keyboard navigation.

<i>Supported By</i>	JAWS
	MAGic
	Dragon
<i>Recommended Evaluation Criteria</i>	Navigation through the page must be equivalent for a graphical page, as it is for a text only page.
<i>Testing Method</i>	<ul style="list-style-type: none"> • Navigate through the text only page. • Ensure that all elements can be assessed, as they are on a non-text only page.

Continued on next page

Section 1194.22.k, Continued

**Requirement
(k.3)**

Text alternative pages must retain color and text size modification capabilities as required by 1194.22.c

<i>Supported By</i>	MAGic
<i>Recommended Evaluation Criteria</i>	The capabilities to change colors and text size must be retained on text only screens.
<i>Testing Method</i>	<ul style="list-style-type: none">• Use the view menu to change the text size.• Use the ignore colors and display options to changes the foreground/background colors. <p>All these capabilities must be available for any text only pages.</p>

Section 1194.22.I

Standard 1194.22.I **When pages utilize scripting languages to display content, or to create interface elements, the information provided by the script shall be identified with functional text that can be read by Assistive Technology.**

SSA Interpretation All Section 508 requirements apply to the functionality provided by any scripting language to display content or to create interface elements.

Requirement (I.1) **Any content or interface elements must be keyboard or voice accessible.**

<i>Supported By</i>	JAWS
	MAGic
	Dragon
<i>Recommended Evaluation Criteria</i>	Keyboard and voice input must be able to navigate to all content and interface elements.
<i>Testing Method</i>	Use the keyboard and voice to navigate content and interface elements. These must be spoken by screen readers accessible by voice.

Requirement (I.2) **Any content or interface element must have a well-defined visual focus.**

<i>Supported By</i>	JAWS
	MAGic
	Dragon
<i>Recommended Evaluation Criteria</i>	Content and interface elements produced by scripting must have focused text equivalents.
<i>Testing Method</i>	Navigate to the content and interface elements to see whether a well-defined visual focus is present.

Continued on next page

Section 1194.22.I, Continued

Requirement (I.3) **Any content or interface element must be accessible to the Assistive Technologies.**

<i>Supported By</i>	JAWS
	MAGic
	Dragon
<i>Recommended Evaluation Criteria</i>	Functional text must be available to the AT
<i>Testing Method</i>	Use the AT to speak, magnify, or navigate to the functional text.

Requirement (I.4) **Sufficient information about a user interface element including the identification, operation and state of the element must be available to the Assistive Technology.**

<i>Supported By</i>	JAWS
	MAGic
	Dragon
<i>Recommended Evaluation Criteria</i>	Any controls or interface elements created by scripting must be accessible to the Assistive Technologies.
<i>Testing Method</i>	The AT must be able to perform their normal function with any controls by scripting.

Section 1194.22.m

Standard 1194.22.m When a web page requires that an applet, plug-in or other application be present on the client system to interpret page content, the page must provide a link to a plug-in or applet that complies with § 1194.21.a through § 1194.21.l

SSA Interpretation AT shall be able to use all plug-ins appropriately with the same functionality as depicted in 1194.21. These include, but are not limited to PDF forms and document, Java applets, Flash, and ActiveX controls.

Requirement (m.1) PDF forms meant to be printed and not filled in online must speak in a logical reading order. That is, fields must speak as fields in the order they appear on the form.

<i>Supported By</i>	JAWS
<i>Recommended Evaluation Criteria</i>	Non-fillable PDF forms must speak from left to right and top to bottom. Multi-line fields take precedence in the reading order and therefore, must speak its content in its entirety before subsequent fields. See 344ha-520.pdf.
<i>Testing Method</i>	Use the Down Arrow key to navigate through the application. The screen reader must speak non-fillable forms in a field by field format in a left to right and top to bottom navigational flow.

Requirement (m.2) PDF documents and forms must retain the same clarity with screen magnification software, as they do when not magnified.

<i>Supported By</i>	MAGic
<i>Recommended Evaluation Criteria</i>	When magnification is increased, characters must not be blurred and images no pixilated.
<i>Testing Method</i>	<ul style="list-style-type: none"> • Verify that smoothing is turned on through the Adobe Reader or Acrobat program. • Navigate through the application with screen magnification levels at 6-8X. • Check for blurring or difficulty in seeing the document or form.

Continued on next page

Section 1194.22.m, Continued

Requirement (m.3)

PDF fillable forms must comply with 1194.21.a-l.

<i>Supported By</i>	JAWS
	MAGic
	Dragon
<i>Recommended Evaluation Criteria</i>	All software requirements apply to a fillable, including but not limited to keyboard access, a well-defined visual focus, all the elements exposed to the assistive technology, ability to changes colors and electronic form compatibility with AT.
<i>Testing Method</i>	Tab through the form to ensure that all elements speak track and are accessible by voice input. A PDF fillable form follows the same Testing Method as a testing an application.

Requirement (m.4)

PDF documents and forms, Java applets, ActiveX controls and any other plug-ins must track with Braille displays.

<i>Supported By</i>	JAWS
<i>Recommended Evaluation Criteria</i>	The Braille display must display position on the screen and also display Braille equivalence to speech.
<i>Testing Method</i>	Look at the Braille display or JAWS Braille Viewer to verify that Braille is being displayed that supports JAWS speech and positional information is shown.

Continued on next page

Section 1194.22.m, Continued

Requirement (m.5) **Java applets must comply with 1194.21.a-l**

<i>Supported By</i>	JAWS
	MAGic
	Dragon
<i>Recommended Evaluation Criteria</i>	Java applets must speak, track and be voice accessible as any other application or screen element.
<i>Testing Method</i>	<ul style="list-style-type: none"> • The current Sun JRE and Java Access Bridge must be installed properly for JAWS and MAGic to speak and track properly. See the Sun Accessibility web page to understand configuration issues.⁸ • For Oracle based applets, the current version of the JInitiator and proper installation of the files contained in the Java Access Bridge are essential. See the Oracle white paper on installation guidelines.⁹ <p>Test these applets with the Assistive Technologies using the same testing methodologies for application testing , stressing keyboard access, focus, elements being exposed color changing, electronic forms, etc.</p>

Continued on next page

⁸ <http://www.sun.com/access/>

⁹ <http://www.oracle.com/accessibility/apps02.html>

Section 1194.22.m, Continued

Requirement (m.6)

ActiveX controls must comply with all applicable section of 1194.24.a-l.

<i>Supported By</i>	JAWS
	MAGic
	Dragon
<i>Recommended Evaluation Criteria</i>	Applications that include ActiveX controls (Intranet eForms) must comply with the key elements of 1194.21, including but not limited to keyboard access, focus, exposure of elements, color changing, and access to electronic forms apply. Any added “dll’s” to enhance speech must be compatible and not conflict with the screen reader. Compliant operation with Braille displays is also mandatory.
<i>Testing Method</i>	Use normal testing methodologies for testing application when looking at ActiveX controls. Pay particular attention to Braille display as this has been problematic in the past. There are some JAWS configuration manager settings that can be used to enhance accessibility. ¹⁰

Requirement (m.7)

Any other plug-ins, including Flash, e-Learning players, or multimedia programs must also be compliant with 1194.21 software requirements.

<i>Supported By</i>	JAWS
	MAGic
	Dragon
<i>Recommended Evaluation Criteria</i>	Any current or future plug-ins must comply with all elements of the software requirements.
<i>Testing Method</i>	Test plug-ins like any other application or screen element.

¹⁰ See ActiveX Manager.doc

Section 1194.22.n

Standard 1194.22.n **When electronic forms are designed to be completed on-line, the form shall allow people using Assistive Technology to access the information, field elements, and functionality required for completion and submission of the form, including all directions and cues.**

SSA Interpretation AT users must have access to all controls, labels, directions, and cues for an electronic form. Electronic forms are defined as “anytime a web page or software program request information from the user is interacting with a form”.

Requirement (n.1) **Screen readers must speak all controls, labels, directions, and cues in a logical order.**

<i>Supported By</i>	JAWS
<i>Recommended Evaluation Criteria</i>	All direction, cues, labels, and instructions must be spoken in order to fill out a field properly.
<i>Testing Method</i>	<ul style="list-style-type: none"> • Navigate through an application. • Test to see whether all information is spoken in order to fill out a form properly.

Requirement (n.2) **Keyboard users must get focus to all controls, labels, directions, and cues.**

<i>Supported By</i>	MAGic
	Dragon
<i>Recommended Evaluation Criteria</i>	Focus must be visible on all controls, directions, and cues.
<i>Testing Method</i>	<ul style="list-style-type: none"> • Navigate through an application • See whether there is a well-defined visual focus on all directions, controls, and cues.

Continued on next page

Section 1194.22.n, Continued

Note!! Error handling has been added to this section.

Requirement (n.3)

Errors can be handled by the use of pop-ups, “red balls”, or any other means to identify an error. Errors can also be displayed after inputting a field or submitting a page.

<i>Supported By</i>	JAWS
	MAGic
	Dragon
<i>Recommended Evaluation Criteria</i>	All errors information must receive focus and navigation to errors must be key-able and productive with a minimum of keystrokes.
<i>Testing Method</i>	<ul style="list-style-type: none"> • If pop-up errors are displayed they must receive focus and speak. • Other indicators of errors must have a well-defined visual focus, speak the error message and provide a means of navigating to successive errors in a productive keyboard manner.

Requirement (n.4)

Voice-recognition users must have access, by voice command, to all Menus, Toolbars, and Field Elements.

<i>Supported By</i>	Dragon
<i>Recommended Evaluation Criteria</i>	Using voice, users must be able to control all elements of the screen including menus, toolbars, and any other navigable elements.
<i>Testing Method</i>	Use voice to gain access to elements of the screen needed to complete the on-screen information

Continued on next page

Section 1194.22.n, Continued

For errors displayed through a pop-up, there are specific requirements:

Requirement (n.5) **A list of errors shall be identified at the top of the page and receive focus.**

<i>Supported By</i>	JAWS
	MAGic
	Dragon
<i>Recommended Evaluation Criteria</i>	Errors must be displayed at the top of a page indicating the number and links to errors or a way to arrive consecutively at errors with the keyboard.
<i>Testing Method</i>	<ul style="list-style-type: none"> • Test for focus on errors at the top of the page; visual focus or hearing the number of errors. • Select first error to see focus moves to that control. • Use the JAWS or MAGic links list command to resurface list of errors.

Requirement (n.6) **Each error on the page is associated with the element in error by some indicator, identifiable by speech or text.**

<i>Supported By</i>	JAWS
	MAGic
	Dragon
<i>Recommended Evaluation Criteria</i>	Error message text must be associated with each error element. All error messages must be understandable in order to correct the error.
<i>Testing Method</i>	Visual and auditory checks of the error messages are associated with each control and error messages must be understandable for correction.

Requirement (n.7) **The user shall have the ability to navigate precisely to each identified error and know precisely where each error is without entire form navigation.**

<i>Supported By</i>	JAWS
	MAGic
	Dragon
<i>Recommended Evaluation Criteria</i>	Techniques must be provided to navigate directly to errors with 3 keystrokes
<i>Testing Method</i>	Navigate to successive errors on a page. Navigation must be within 3 keystrokes of moving through errors within a field.

Section 1194.22.o

Standard 1194.22.o **A method shall be provided that permits users to skip repetitive navigation links.**

SSA Interpretation AT and other keyboard users shall be able to skip over repetitive navigation links. Skip Navigation links must be tested to actually skip over repetitive links and move focus to a logical control or text area. Additionally, the skip navigation link must be either made visible or become visible when tabbed to. Frames should not be used to skip repetitive links.

Requirement (o.1) **Provide links/methods to skip over redundant links.**

<i>Supported By</i>	JAWS
	MAGic
	Dragon
<i>Recommended Evaluation Criteria</i>	A skip navigation link must be provided to move/avoid repetitive links.
<i>Testing Method</i>	Select the skip navigation link. Identify whether the focus has changed.

Requirement (o.2) **Links must be visible/made visible when tabbed.**

<i>Supported By</i>	MAGic
	Dragon
<i>Recommended Evaluation Criteria</i>	Skip Navigation links must be visible to keyboard users or become visible when tabbed
<i>Testing Method</i>	<ul style="list-style-type: none"> • If pop-up errors are displayed they must receive focus and speak. • Other indicators of errors must have a well-defined visual focus, speak the error message and provide a means of navigating to successive errors in a productive keyboard manner.

Continued on next page

Section 1194.22.o, Continued

**Requirement
(o.3)**

Focus must be past the repetitive links and to the next control after the skip link is invoked and the next tab is keyed.

<i>Supported By</i>	JAWS
	MAGic
	Dragon
<i>Recommended Evaluation Criteria</i>	When selected, skip links must focus and be a visible shift and the anchor must move so that the next tab is past redundant links.
<i>Testing Method</i>	<ul style="list-style-type: none">• Select the skip link.• Tab to see whether the focus is now on the next link or control after the repetitive link.

Section 1194.22.p

Standard 1194.22.p When a timed response is required, the user shall be alerted and given sufficient time to indicate more time is required.

SSA Interpretation AT users shall be provided information detailing each of the following occurrences:

Conditions	
1	If an application/page has a time out feature
2	When an application/page time out occurs
3	How to request more time to complete the application/page

This information shall be readily spoken by the screen reader and represented by a

Requirement (p.1) If there is a “time-out” feature, users must be clearly advised up-front in the application that it exists.

<i>Supported By</i>	JAWS
	MAGic
	Dragon
<i>Recommended Evaluation Criteria</i>	There must be on screen documentation or a separate Help screen that describes the time-out feature.
<i>Testing Method</i>	Look for documentation at the beginning of an application, detailing the time-out capability

Requirement (p.2) The time-out message must pop-up, speak, and get focus.

<i>Supported By</i>	JAWS
	MAGic
	Dragon
<i>Recommended Evaluation Criteria</i>	The time-out message must be accessible to the AT when displayed.
<i>Testing Method</i>	When the message appears, verify that it speaks/has focus.

Continued on next page

Section 1194.22.p, Continued

**Requirement
(p.3)**

Users must have time to initiate actions allowing time extensions.

<i>Supported By</i>	JAWS
	MAGic
	Dragon
<i>Recommended Evaluation Criteria</i>	There must be at least 5 minutes allowed to extend the time needed to continue the application
<i>Testing Method</i>	After the message appears, initiate the action to extend the time-out period.

**Requirement
(p.4)**

If users time-out, they must have the capability to return easily to the last addressed page.

<i>Supported By</i>	JAWS
	MAGic
	Dragon
<i>Recommended Evaluation Criteria</i>	Once the application has timed-out, the user must be able to return (within 3 keystrokes) to the last addressed page.
<i>Testing Method</i>	Navigate back to the discontinued page after timing-out within 3 keystrokes. Ensure that the instructions are clear on how to get back where you were.

Section 1194.22 End

Telecommunications

Section 1194.23.a

Standard 1194.23.a Telecommunication products or systems which provide a function allowing voice communication and which do not themselves provide a TTY functionality shall provide a standard non-acoustic connection point with TTYs. Microphones shall be capable of being turned on and off to allow the user to intermix speech with TTY use.

SSA Interpretation A TTY (Teletypewriter) uses two-way text conversation over an analog phone line. Tones are converted to text using ANSI/TIA/EIA 835 and Baudot specifications. Voice Carry Over allows people who can use speech to converse and Hearing Carry Over (HCO) allows people to use their hearing, but not speech. Therefore, VCO allows for text to be received and HCO allows for text to be sent.

Requirement (a.1) Provide a standard non-acoustic connection point for TTYs.

<i>Supported By</i>	Dragon Deaf/Hard of Hearing
<i>Recommended Evaluation Criteria</i>	Verify a standard non-acoustic connection point if product does not provide TTY functionality.
<i>Testing Method</i>	Test the ability to send and receive text messages.

Requirement (a.2) Provide the capability for a microphone to be turned on and off.

<i>Supported By</i>	Dragon Deaf/Hard of Hearing
<i>Recommended Evaluation Criteria</i>	Ability to switch the microphone on or off to provide VCO and HCO
<i>Testing Method</i>	Turn on microphone for VCO and turn it off for HCO

Requirement (a.3) TTY must support 45.5 baud Baudot.

<i>Supported By</i>	Dragon Deaf/Hard of Hearing
<i>Recommended Evaluation Criteria</i>	Works with VCO
<i>Testing Method</i>	Test 45.5 baud with VCO to ensure functionality

Section 1194.23.b

Standard 1194.23.b **Telecommunications and products which include voice communication functionality shall support all commonly used cross-manufacturer non-proprietary standard TTY signal protocols.**

SSA Interpretation This provision requires support for 45.5 baud Baudot as the fast 300 baud can be problematic with Voice Carry Over. Although 300 baud Baudot is also required (used for downloading capability) it is not a requirement for VCO.

Requirement (b.1) **Provide 45.5 baud Baudot functionality to interoperate with Voice Carry Over (VCO).**

<i>Supported By</i>	Dragon Deaf/Hard of Hearing
<i>Recommended Evaluation Criteria</i>	Use 45.5 baud Baudot with VCO to ensure compatibility.
<i>Testing Method</i>	<ul style="list-style-type: none">• Select 45.5 Baudot to make a TTY call using VCO• Check, send, and receive reliability with text coming and going• Verify results

Requirement (b.2) **Provide functionality to use TTY over VoIP.**

<i>Supported By</i>	Dragon Deaf/Hard of Hearing
<i>Recommended Evaluation Criteria</i>	Wireless carriers must inform FVCC when their networks are compatible
<i>Testing Method</i>	Independent testing required to ensure handsets are TTY compatible.

Section 1194.23.c

Standard 1194.23.c **Voice mail, auto-attendant, and interactive voice response telecommunications systems shall be usable by TTY users with the TTYs.**

Requirement (c.1) **Voice mail must be receivable by TTY devices.**

<i>Supported By</i>	Dragon Deaf/Hard of Hearing
<i>Recommended Evaluation Criteria</i>	Use the TTY device to display voice mail.
<i>Testing Method</i>	Accessing the functionality of the TTY device displays the text messages (voice mail)

Requirement (c.2) **TTY devices must capture and integrate with auto-attendant messages.**

<i>Supported By</i>	Dragon Deaf/Hard of Hearing
<i>Recommended Evaluation Criteria</i>	Auto-attendant messages must display text equivalents.
<i>Testing Method</i>	Use the features of the TTY device to display text-based auto-attendant messages.

Requirement (c.3) **Users must be able to use Interactive Voice Response (IVR) systems through TTYs comparably Voice IVRs.**

<i>Supported By</i>	Dragon Deaf/Hard of Hearing
<i>Recommended Evaluation Criteria</i>	Must be capable of producing interactive text response equivalent to voice response systems.
<i>Testing Method</i>	Press the number keys on a TTY to interactively communicate with an IVR system.

Section 1194.23.d

Standard 1194.24.d Voice mail, messaging, auto-attendant, and interactive voice response telecommunications systems that require a response from a user with a time interval, shall give an alert when the time interval is about to run out, and shall provide sufficient time for the user to indicate more time is required.

Requirement (d.1) Any time-out requirement must be alerted to non-audibly.

<i>Supported By</i>	Dragon Deaf/Hard of Hearing
<i>Recommended Evaluation Criteria</i>	Time-out requirement must produce text equivalents accessed through TTY.
<i>Testing Method</i>	Observe the TTY for time-out messages when time response is imposed.

Requirement (d.2) The user must be alerted when time is going to run out.

<i>Supported By</i>	Dragon Deaf/Hard of Hearing
<i>Recommended Evaluation Criteria</i>	Before time-outs occur, user must receive text warning.
<i>Testing Method</i>	Observe warning for time-outs on the TTY device.

Requirement (d.3) The user must have sufficient time to extend the response time required.

<i>Supported By</i>	Dragon Deaf/Hard of Hearing
<i>Recommended Evaluation Criteria</i>	At least 5 minutes must be provided to extend the time period.
<i>Testing Method</i>	Note time-out period in order to extend time-out messages.

Section 1194.23.e

**Standard
1194.24.e**

Where provided, caller identification and similar telecommunications function shall also be available for users of TTYs and for users who cannot see displays.

**Requirement
(e)**

Caller ID and other information data transmitted to visual display must be available on TTY for deaf and blind users.

<i>Supported By</i>	JAWS Dragon Deaf/Hard of Hearing
<i>Recommended Evaluation Criteria</i>	Called ID messages displayed through the TTY device.
<i>Testing Method</i>	Make a call to a TTY and determine if caller ID appears on display.

Standard 1194.23.f

**Standard
1194.24.f**

For transmitted voice signals, telecommunications products shall provide a gain adjustable up to a minimum of 20 dB. For incremental volume control, at least one intermediate step of 12 dB of gain shall be provided.

**Requirement
(f.1)**

The telecommunications product must provide a volume control adjustable to a minimum of 20 dB.

<i>Supported By</i>	Dragon Deaf/Hard of Hearing
<i>Recommended Evaluation Criteria</i>	The volume control must be adjustable to at least 20 dB.
<i>Testing Method</i>	Use a decibel measuring device to record adjustability of volume controls.

**Requirement
(f.2)**

For incremental volume control, at least one intermediate step of 12 dB must be provided.

<i>Supported By</i>	Dragon Deaf/Hard of Hearing
<i>Recommended Evaluation Criteria</i>	Provide incremental volume control at a minimum of one 12 dB steps
<i>Testing Method</i>	Use a decibel measuring device to check the incremental volume control.

Section 1194.23.g

Standard 1194.24.g **If the telecommunications product allows a user to adjust the receiver volume, a function shall be provided to automatically reset the volume to the default level after every use.**

Requirement (g) **If the product allows for adjusting the receiver volume, capability to reset to default level must exist.**

<i>Supported By</i>	Dragon Deaf/Hard of Hearing
<i>Recommended Evaluation Criteria</i>	The ability to reset the volume must be established
<i>Testing Method</i>	Reset the volume to the default value after each use.

Standard 1194.23.h

**Standard
1194.24.h**

Where a telecommunications product delivers output by an audio transducer which is normally held up to the ear, a means for effective magnetic wireless coupling to hearing technologies shall be provided.

**Requirement
(h.1)**

Requirement for hearing aids to be compatible with the telecommunications product.

<i>Supported By</i>	Dragon Deaf/Hard of Hearing
<i>Recommended Evaluation Criteria</i>	Hearing aids must be operable with telecommunications products
<i>Testing Method</i>	Use a hearing aid with telecommunications devices to determine any interoperability.

**Requirement
(h.2)**

This also applies to other hearing devices, i.e. cochlear implants, assistive listening devices.

<i>Supported By</i>	Dragon Deaf/Hard of Hearing
<i>Recommended Evaluation Criteria</i>	Other hearing devices must be able to receive communications from telecommunications products.
<i>Testing Method</i>	Use a wireless phone to determine if communication is possible with alternative hearing devices.

Section 1194.23.i

Standard 1194.24.i Interference to hearing technologies (including hearing aids, cochlear implants, and assistive listening devices) shall be reduced to the lowest possible level that allows a user of hearing technologies to utilize the telecommunications product.

Requirement (i.1) ANSI C63.192001 provides procedures to test the interference level produced by handsets.

<i>Supported By</i>	Dragon Deaf/Hard of Hearing
<i>Recommended Evaluation Criteria</i>	Interference must not prevent users from successfully operating assistive hearing devices.
<i>Testing Method</i>	Reference ANSI C63.19-2001 to test interference levels.

Requirement (i.2) Code Division Multiple Access (CDMA) based technologies tend to cause less interference than Group Spécial Mobile (GSM) technologies.

<i>Supported By</i>	Dragon Deaf/Hard of Hearing
<i>Recommended Evaluation Criteria</i>	CDMA based technologies are preferred over GSM to reduce interference.
<i>Testing Method</i>	<p>Compare the interference levels between CDMA and GSM based technologies using ANSI procedures. ANSI C63.19-2001 provides procedures to measure electromagnetic emissions produced by wireless/cellular handsets.</p> <p>The standard provides 2 summary test results, one for radio frequency emission that creates a bussing noise in hearing aids, primarily when in microphone (default) setting, and one for use with a hearing aid's telecoil.</p> <p>For each result, there are four levels defined (4 is the best; lowers emission category). The FCC has set a minimum of category 3 for telephones consider (and labeled) as compatible with hearing aids. (The FCC rule goes into effect in 2005.)</p> <p>The FCC's rule includes consideration of interference for determining "hearing aid compatibility."</p>

Section 1194.23.j

Standard 1194.24.j Products that transmit or conduct information or communication, shall pass through cross-manufacturer, non-proprietary, industry-standard codes, translation protocols, formats or other information necessary to provide the information or communication in a usable format. Technologies which use encoding, signal compression, format transformation, or similar techniques shall not remove information needed for access or shall restore it upon delivery.

Requirement (j.1) The retention of captioning and audio description must be available in the reformatting and transmission processes.

<i>Supported By</i>	Dragon Deaf/Hard of Hearing
<i>Recommended Evaluation Criteria</i>	All captioning/audio description available to user.
<i>Testing Method</i>	Test for captioning and audio description for multimedia transmission.

Requirement (j.2) Products must not strip out captioning and timing information so that synchronization can occur between audio and video.

<i>Supported By</i>	Dragon Deaf/Hard of Hearing
<i>Recommended Evaluation Criteria</i>	Caption must be synchronized with the presentation.
<i>Testing Method</i>	Ensure that captioning coincides with information display on screen in synchronized manner.

Requirement (j.3) TTY signals applied to VoIP and other emerging technologies must remain intact.

<i>Supported By</i>	Dragon Deaf/Hard of Hearing
<i>Recommended Evaluation Criteria</i>	TTY signals must be transmitted over VoIP devices.
<i>Testing Method</i>	Test for TTY signals (text, messages) when using VoIP devices.

Section 1194.23.k₁₋₄

Standard 1194.24.k₁ **Products which have mechanically operated controls or keys shall comply with the following: Controls and Keys shall be tactilely discernible without activating the controls or keys.**

SSA Interpretation All controls and keys must be distinguishable by themselves using tactile or other means to differentiate them from other keys.

Requirement (k_{1.1}) **Keys and controls must e located and distinguished from adjacent objects by touch.**

<i>Supported By</i>	JAWS MAGic Dragon
<i>Recommended Evaluation Criteria</i>	Use touch along to distinguish keys and controls.
<i>Testing Method</i>	Close your eyes and use touch to distinguish keys and controls.

Requirement (k_{1.2}) **Braille or raised labels can be used to satisfy this requirement.**

<i>Supported By</i>	JAWS MAGic
<i>Recommended Evaluation Criteria</i>	Attach Braille labels to controls
<i>Testing Method</i>	Use the Braille labels to select keys and controls.

Requirement (k_{1.3}) **Identifying keys tactilely must not activate keys or controls.**

<i>Supported By</i>	JAWS MAGic Dragon Deaf/Hard of Hearing
<i>Recommended Evaluation Criteria</i>	Identifying keys tactilely must not activate keys or controls.
<i>Testing Method</i>	Identify keys with hand to determine pressure sensitivity.

Continued on next page

Section 1194.23.k1-4₁₋₄, Continued

Standard 1194.24.k₂ **Products which have mechanically operated controls or keys shall comply with the following:**
Controls and keys...

- ...shall be operable with one hand,
- shall not require tight grasping, pinching, or twisting of the wrist, and
- the force required to activate shall be 5 lbs. (22.2 N) maximum.

SSA Interpretation Controls and keys must be operable by people with dexterity issues, users with one hand, and people with hand strength problems.

Requirement (k₂.1) **All controls and keys must be operable with one hand and not require special wrist actions to activate the control.**

<i>Supported By</i>	Dragon Mobility
<i>Recommended Evaluation Criteria</i>	With one hand, operate a key or control without using special wrist contortions.
<i>Testing Method</i>	Use one hand to select a control or key without twisting the wrist.

Requirement (k₂.2) **All controls and keys must be large enough and distanced enough for those with dexterity issues to operate.**

<i>Supported By</i>	MAGic Dragon Mobility
<i>Recommended Evaluation Criteria</i>	Multiple keys or controls must not be activated together.
<i>Testing Method</i>	If there is a visual indicator, listen for an auditory equivalent. Check also for a method to discern tactilely a change in state.

Continued on next page

Section 1194.23.k1-4₁₋₄, Continued

Standard 1194.24.k₃ Products which have mechanically operated controls or keys shall comply with the following: If key repeat is supported, the delay before repeat shall be adjustable to at least 2 seconds. Key repeat rate shall be adjustable to 2 seconds per character.

Requirement (k_{3.1}) If key repeat is present, it must be tested for startup delay and repeat rate.

<i>Supported By</i>	Dragon Mobility
<i>Recommended Evaluation Criteria</i>	10 second key engagement without activation.
<i>Testing Method</i>	<ul style="list-style-type: none"> • Press for 10 seconds • If no key repeat is observed, the function does not exist.

Requirement (k_{3.2}) The key repeat start up delay must be adjustable to 2 seconds.

<i>Supported By</i>	Dragon Mobility
<i>Recommended Evaluation Criteria</i>	Repeat rate must occur after 2 seconds.
<i>Testing Method</i>	<ul style="list-style-type: none"> • Set delay to maximum • Hold key and note when first repeated • Confirm 2 second standard

Requirement (k_{3.3}) Key repeat rate must be adjustable to 2 seconds per character.

<i>Supported By</i>	Dragon Mobility
<i>Recommended Evaluation Criteria</i>	Repeat rate must occur after 2 seconds.
<i>Testing Method</i>	<ul style="list-style-type: none"> • Set repeat rate to maximum value • Hold key until it has repeated at least 4 times • Measure time between the fifth and sixth repeat

Continued on next page

Section 1194.23.k1-4₁₋₄, Continued

Standard 1194.24.k₄ **Products which have mechanically operated controls or keys shall comply with the following: The status of all locking or toggle controls or keys shall be visually discernible, and discernible either through touch or sound.**

SSA Interpretation All locking or toggle controls must provide a means of identifying the state of the control. This must be through visual, auditory or tactile cues.

Requirement (k_{4.1}) **All locking or toggle controls must be visually discernible.**

<i>Supported By</i>	JAWS MAGic
<i>Recommended Evaluation Criteria</i>	Must be visual indicator of locking or toggle controls.
<i>Testing Method</i>	Press a locking or toggle control to determine visual indicator of its state.

Requirement (k_{4.2}) **For any visually discernible control there must be an equivalent audible or tactile indicator.**

<i>Supported By</i>	JAWS MAGic
<i>Recommended Evaluation Criteria</i>	Visual indicators must have an alternative audible or tactile indicator.
<i>Testing Method</i>	If there is a visual indicator, list for an auditory equivalent. Check also for a method to discern tactilely a change in state.

Section 1194.23 End

Video and Multimedia

Section 1194.24.a

**Standard
 1194.24.a**

All analog television displays 13 inches and larger, and computer equipment that includes analog television receiver or display circuitry, shall be equipped with caption decoder circuitry which appropriately receives, decodes, and displays closed captions from broadcast, cable, videotape, and DVD signals. As soon as practicable, but not later than July 1, 2002, widescreen digital television (DTV) displays measuring at least 7.8 inches vertically, DTV sets with conventional displays measuring at least 13 inches vertically, and stand-alone DTV tuners, whether or not they are marketed with display screens, and computer equipment that includes DTV receiver or display circuitry, shall be equipped with caption decoder circuitry which appropriately receives, decodes, and displays closed captions from broadcast, cable, videotape, and DVD signals.

**Requirement
 (a)**

Televisions must have capability to display both open and closed captions

<i>Supported By</i>	Dragon Deaf/Hard of Hearing
<i>Recommended Evaluation Criteria</i>	Televisions must have capability to display both open and closed captions.
<i>Testing Method</i>	<ul style="list-style-type: none"> • Play a video known to have captions • Check for the display

Section 1194.24.b

Standard
1194.24.b

Television tuners, including tuner cards for use in computers, shall be equipped with secondary audio program playback circuitry.

Requirement
(b)

All television and tuners must provide for secondary audio capability.

<i>Supported By</i>	JAWS
	Blind
	Dragon
	Deaf/Hard of Hearing
<i>Recommended Evaluation Criteria</i>	Be able to provide descriptive audio on secondary audio channel.
<i>Testing Method</i>	Test a program with known secondary audio.

Section 1194.24.c

Standard 1194.24.c All training and informational video and multimedia productions which support the agency's mission, regardless of format, that contain speech or other audio information necessary for the comprehension of the content, shall be open or closed captioned.

Requirement (c.1) Training, informational videos and multimedia productions containing speech and supporting the agency's mission must contain open or closed captioning.

<i>Supported By</i>	Dragon Deaf/Hard of Hearing
<i>Recommended Evaluation Criteria</i>	Open or closed captioning must be evident when speech is used for training materials.
<i>Testing Method</i>	Look for captioning on videos and multimedia productions.

Requirement (c.2) This requirement does not provide alternatives such as text equivalents.

<i>Supported By</i>	Dragon Deaf/Hard of Hearing
<i>Recommended Evaluation Criteria</i>	Text equivalents cannot be used to replace speech
<i>Testing Method</i>	Ensure that text is synchronized with speech so there is not a separate text alternative.

Requirement (c.3) This also applies to software applications that use speech; captioning must be synchronized with the presentation.

<i>Supported By</i>	Dragon Deaf/Hard of Hearing
<i>Recommended Evaluation Criteria</i>	Open or closed captioning must be evident when speech is used for training materials.
<i>Testing Method</i>	Look for captioning on videos and multimedia productions.

Section 1194.24.d

Standard 1194.24.d All training and informational video and multimedia productions which support the agency's mission, regardless of format, that contain visual information necessary for the comprehension of the content, shall be audio described.

Requirement (d.1) All training and informational videos and multimedia productions containing visual information and supporting the agency's mission must be audio described.

<i>Supported By</i>	JAWS Blind
<i>Recommended Evaluation Criteria</i>	Descriptive audio must be provided for visual presentations used for training materials.
<i>Testing Method</i>	Ensure descriptive audio is present for visual training materials.

Requirement (d.2) Any audio description must be careful not to interfere or conflict with screen readers.

<i>Supported By</i>	JAWS Blind
<i>Recommended Evaluation Criteria</i>	Speech and screen must not speak simultaneously.
<i>Testing Method</i>	Turn on JAWS and ensure that inherent speech does not initiate at the same time as the screen reader is speaking.

Section 1194.24 End

Self-Contained, Closed Products

Section 1194.25.a

Standard 1194.25.a **Self-contained products shall be usable by people with disabilities without requiring an end-user to attach Assistive Technology to the product. Personal headsets for private listening are not Assistive Technology.**

SSA Interpretation Usability for this requirement is demonstrated by compliance with provisions 1194.25(b-j4) and 1194.31, functional requirements. Additionally, when the self-contained closed product is being used as a computer peripheral or is connected to a network, other portions of Section 508 will normally apply.

Requirement (a.1) **When a digital display is used to provide visual information, and the device is used as a computer peripheral or is connected to a network, there must be an alternative provided for vision disabled users.**

<i>Supported By</i>	JAWS
	MAGic
<i>Recommended Evaluation Criteria</i>	The preferable alternative is to provide a software based alternative provided on an attached computer. The information provided on the digital display must be comparable to what is produced through software on the accompanying computer.
<i>Testing Method</i>	Use JAWS, MAGic, and Dragon to access web or software based applications on computers. Sections 1194.21, 1194.22, and 1194.31 apply here.

Requirement (a.2) **When the device is not connected to a network or a computer, it must stand alone in providing comparable access to people with disabilities.**

<i>Supported By</i>	JAWS
	MAGic
	Dragon
<i>Recommended Evaluation Criteria</i>	Sound, alternatives, increased font size, contrast controls, and text equivalents for sound must be provided.
<i>Testing Method</i>	Any visual display must have speech alternatives, and the ability to produce increased font sizes and contrast. Any audible tones must have comparable text alternatives.

Section 1194.25.b

**Standard
1194.25.b**

When time response is required, the user shall be alerted and given sufficient time to indicate more time is required.

**Requirement
(b.1)**

Alerts must be accessible for the various disabilities.

<i>Supported By</i>	JAWS
	MAGic
	Dragon
	Deaf/Hard of Hearing
<i>Recommended Evaluation Criteria</i>	Visual alerts must have speech alternatives. Audible alerts must have textual alternatives. These must be repeatable.
<i>Testing Method</i>	<ul style="list-style-type: none"> • Test visual alerts for speech alternatives • Test audible alerts for text. • Determine if alerts are repeatable

**Requirement
(b.2)**

Additional time must be provided or a repeat must be generated.

<i>Supported By</i>	JAWS
	MAGic
	Dragon
<i>Recommended Evaluation Criteria</i>	There must be a visual indicator that additional time is available.
<i>Testing Method</i>	Ensure the capability that additional time can be activated when it is so indicated.

Section 1194.25.c

Standard
1194.25.c **Where a product utilized touch screens or contact-sensitive controls, an input method shall be provided that complies with 1194.23.k₁₋₄.**

Special Note!! **See Requirements for 1194.23.k₁₋₄.**

Section 1194.25.d

Standard 1194.25.d **When biometric forms of user identification or control are used, an alternative form of identification or activation, which does not require the user to possess particular biological characteristics, shall also be provided.**

SSA Interpretation Passwords can be used as an acceptable alternative to a biometric form of user ID or control. This alternative must then comply with the provisions of Section 1194.

Artificial limbs or eyes may not be suitable for passing biometric tests that rely on fingerprint or retinal scans.

Requirement (d.1) **Fingerprinting may not be suitable for mobility impaired users; alternatives must be provided.**

<i>Supported By</i>	Dragon
	Deaf/Hard of Hearing
<i>Recommended Evaluation Criteria</i>	Provide alternatives for fingerprinting identification techniques.
<i>Testing Method</i>	Test alternative identification for electronic access.

Requirement (d.2) **Retinal scans may not be suitable for blind users as positioning may be critical; alternatives must be provided.**

<i>Supported By</i>	JAWS
<i>Recommended Evaluation Criteria</i>	Provide alternative identification capabilities besides retinal scans.
<i>Testing Method</i>	Test alternative identification for electronic access.

Requirement (d.3) **If feedback is provided upon (un)successful identification, this information must also be in an accessible format.**

<i>Supported By</i>	JAWS
	MAGic
	Dragon
<i>Recommended Evaluation Criteria</i>	Unsuccessful identification must be provided in an accessible format.
<i>Testing Method</i>	Test for auditory or visual means of producing unsuccessful identification.

Section 1194.25.e

**Standard
 1194.25.e**

When products provide auditory output, the audio signal shall be provided at a standard signal level through an industry standard connector that will allow for private listening. The product must provide the ability to interrupt, pause and restart the audio at anytime.

**Requirement
 (e.1)**

Auditory output must provide for the ability to interrupt, pause, and restart audio. These controls must comply with Section 1193.23 k₁₋₄.

<i>Supported By</i>	JAWS
	MAGic
	Dragon
	Deaf/Hard of Hearing
<i>Recommended Evaluation Criteria</i>	Interruption, pausing, and restart must be provided for auditory output and be keyboard, control, or voice accessible.
<i>Testing Method</i>	Use the keyboard control or voice to interrupt, pause, and restart auditory output.

**Requirement
 (e.2)**

Hearing aids, cochlear implants, and assistive listening devices must interoperate with the auditory output.

<i>Supported By</i>	Dragon
	Deaf/Hard of Hearing
<i>Recommended Evaluation Criteria</i>	Hearing aids, cochlear implants, and assistive listening devices must interoperate with the auditory output.
<i>Testing Method</i>	Use assistive hearing devices with any auditory output device to ensure operability.

Section 1194.25.f

**Standard
1194.25.f**

When products deliver voice output in a public area, incremental volume control shall be provided with output amplification up to a level of at least 65 dB.

Where the ambient noise level of the environments is above 44 dB, a volume gain of at least 20 dB above the ambient level shall be user selectable. A function shall be provided to automatically reset the volume to the default level after every use.

**Requirement
(f.1)**

This provision does not require interoperability with AT.

<i>Supported By</i>	Dragon
	Deaf/Hard of Hearing
<i>Recommended Evaluation Criteria</i>	User selectable volume gain of 20 dB must be provided
<i>Testing Method</i>	Use a decibel measuring device to determine volume gain capability.

Section 1194.25.g

Standard 1194.25.g **Color coding shall not be used as the only means of conveying information, indicating action, prompting a response, or distinguishing a visual element.**

Requirement (g.1) **Any use of color must not be the only means of conveying information.**

<i>Supported By</i>	JAWS
	MAGic
<i>Recommended Evaluation Criteria</i>	Color cannot be sole means of conveying information.
<i>Testing Method</i>	Determine if color is the only indicator of an action prompting a response through the distinguishing of color.

Requirement (g.2) **Controls, lights and error messages that use color must have alternative means of conveying the same information.**

<i>Supported By</i>	JAWS
	MAGic
<i>Recommended Evaluation Criteria</i>	Color cannot be sole means of conveying information.
<i>Testing Method</i>	Color indicators must have alternatives to distinguish its meaning.

Requirement (g.3) **The alternative to color must be accessible with and without AT.**

<i>Supported By</i>	JAWS
	MAGic
<i>Recommended Evaluation Criteria</i>	The alternative to color must be accessible with and without AT.
<i>Testing Method</i>	Test for alternatives for color with and without using AT.

Section 1194.25.h

Standard 1194.25.h When a product permits a user to adjust the color and contrast settings, range of color selections capable of producing a variety of contrast levels shall be provided.

Requirement (h.1) When products provide color and contrast adjustments, there must be a range provided to meet individual needs.

<i>Supported By</i>	MAGic
<i>Recommended Evaluation Criteria</i>	www.lighthouse.org/color_contrast.htm is a good guideline.
<i>Testing Method</i>	Use the Lighthouse color/contrast guide.

Requirement (h.2) Soft backgrounds with low contrast color schemes and high contrast color schemes must be provided.

<i>Supported By</i>	MAGic
<i>Recommended Evaluation Criteria</i>	Ex: white on black, black on white and yellow on black
<i>Testing Method</i>	Check for high contrast capabilities.

Requirement (h.3) Reds and greens should be avoided.

<i>Supported By</i>	MAGic
<i>Recommended Evaluation Criteria</i>	Avoid red and green combinations.
<i>Testing Method</i>	Test for red and green combinations that impair contrast.

Section 1194.25.i

Standard
1194.25.i

Products shall be designed to avoid causing the screen to flicker with a frequency greater than 2 Hz and lower than 55 Hz.

Note!! See 1194.21.k

Section 1194.25.j₁₋₄

Standard
1194.25.j₁

Products which are freestanding, non-portable, and intended to be used in one location and which have operable controls shall comply with the following: The position of any operable control shall be determined with respect to a vertical plane, which is 48 inches in length, centered on the operable control, and at the maximum protrusion of the product with the 48 inch length.

SSA Interpretation

Operable controls include but are not limited to mechanically operated controls, input and output trays, card slots, keyboards and keypads.

Continued on next page

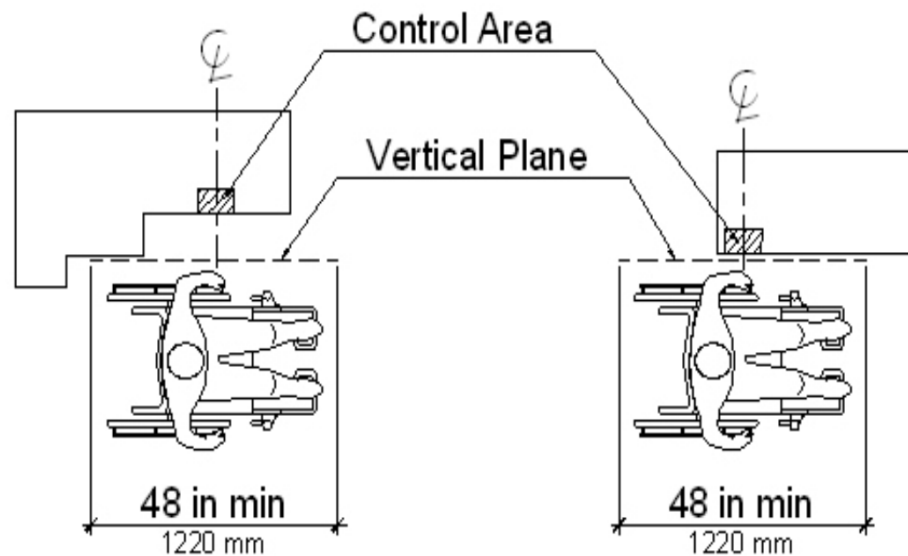

Vertical Plane Relative to the Operable Control

Figure 1

Section 1194.25.j1-4, Continued

Requirement (j1.a)

This requirement pertains to controls used in normal daily operation.

<i>Supported By</i>	Dragon
	Mobility
<i>Recommended Evaluation Criteria</i>	People with mobility disabilities must be able to reach all controls used in daily operations.
<i>Testing Method</i>	With one hand, use a chair to see if controls can be reached.

Requirement (j1.b)

Monitoring functions are considered normal daily use.

<i>Supported By</i>	Dragon
	Mobility
<i>Recommended Evaluation Criteria</i>	People with mobility disabilities must be able to perform monitoring activities.
<i>Testing Method</i>	Any monitoring activities must include ability to reach all controls.

Refer to Figure 1

Continued on next page

Section 1194.25.j₁₋₄

Standard
 1194.25.j₁

Products which are freestanding, non-portable, and intended to be used in one location and which have operable controls shall comply with the following: The position of any operable control shall be determined with respect to a vertical plane, which is 48 inches in length, centered on the operable control, and at the maximum protrusion of the product with the 48 inch length.

SSA Interpretation

Operable controls include but are not limited to mechanically operated controls, input and output trays, card slots, keyboards and keypads.

Requirement (j_{1.a})

This requirement pertains to controls used in normal daily operation.

<i>Supported By</i>	Dragon
	Mobility
<i>Recommended Evaluation Criteria</i>	People with mobility disabilities must be able to reach all controls used in daily operations.
<i>Testing Method</i>	With one hand, use a chair to see if controls can be reached.

Requirement (j_{1.b})

Monitoring functions are considered normal daily use.

<i>Supported By</i>	Dragon
	Mobility
<i>Recommended Evaluation Criteria</i>	People with mobility disabilities must be able to perform monitoring activities.
<i>Testing Method</i>	Any monitoring activities must include ability to reach all controls.

Refer to Figure 1

Continued on next page

Section 1194.25.j₁₋₄, Continued

Standard
1194.25.j₂

Products which are freestanding, non-portable, and intended to be used in one location and which have operable controls shall comply with the following: Where any operable control is 10 inches or less behind the reference plane, the height shall be 54 inches maximum and 15 inches minimum above the floor.

SSA Interpretation

Operable controls include but are not limited to mechanically operated controls, input and output trays, card slots, keyboards, and keypads.

Requirement (j_{2-a})

The requirement must automatically drop exactly to the 46 inch maximum height after the 10 inch (depth) limit has been reached.

<i>Supported By</i>	Dragon
	Mobility
<i>Recommended Evaluation Criteria</i>	The requirement must adhere to the 46 in. max height/10 in. depth limit restrictions.
<i>Testing Method</i>	Test for the minimum and maximum heights.

Requirement (j_{2-b})

All operable controls, excluding maintenance, are included in this requirement.

<i>Supported By</i>	JAWS
	MAGic
	Dragon
<i>Recommended Evaluation Criteria</i>	All operable controls, excluding maintenance functions, must comply with the minimum and maximum heights.
<i>Testing Method</i>	Test all controls excluding maintenance functions.

Continued on next page

Section 1194.25.j₁₋₄, Continued

Standard
1194.25.j₃

Products which are freestanding, non-portable, and intended to be used in one location and which have operable controls shall comply with the following: Where any operable control is more than 10 inches and not more than 24 inches behind the reference plane, the height shall be 46 inches maximum and 15 inches minimum above the floor.

Note!! The j₁ and j₂ Requirements are applicable here.

Refer to Figure 2

Continued on next page

Section 1194.25.j₁₋₄, Continued

Standard
 1194.25.j₄

Products which are freestanding, non-portable, and intended to be user in one location and which have operable controls shall comply with the following: Operable controls shall not be more that 24 inches behind the reference plane.

Requirement
 (j₄. a)

<i>Supported By</i>	Dragon
<i>Recommended Evaluation Criteria</i>	Operable controls must not be more than 24 inches behind the reference plane.
<i>Testing Method</i>	Test operable controls for this 24 inch requirement.

Refer Figure 2

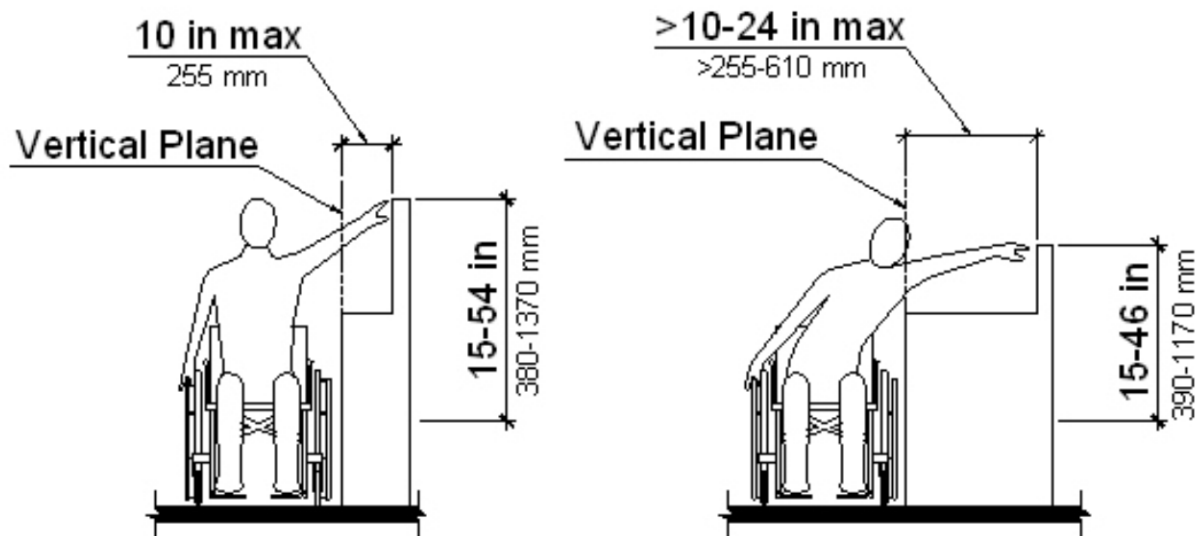

Height of Operable Control Relative to the Vertical Plane

Figure 2

Desktop and Portable Computers

Section 1194.26

Standard 1194.26.a All mechanically operated controls and keys shall comply with 1194.23.k₁₋₄

Requirement (a.1) See 1194.23.k₁₋₄

Requirement (a.2) Clearly labeled keys, indicators, and slots or alternatives for such, should be accessible and understandable.

<i>Supported By</i>	JAWS
	MAGic
	Dragon
<i>Recommended Evaluation Criteria</i>	Keys on keyboards and all other labeled controls must be readable by people with disabilities.
<i>Testing Method</i>	Observe the keyboard for lettering, contrast, font size to see if all keys and controls are accessible. If not consistent, determine if alternative labeling is available or been supplied.

Requirement (a.3) All lights on computers, keyboards, mice, or other integrally connected devices must have alternative indicators of these colors.

<i>Supported By</i>	JAWS
	MAGic
<i>Recommended Evaluation Criteria</i>	All lights on computer, keyboards, mice or other integrally connected devices must have alternative indicators of these colors.
<i>Testing Method</i>	Use screen readers auditory indicators or check labels to for alternatives to colored lights used to convey information.

Section 1194.26.b

**Standard
 1194.26.b**

If a product utilizes touch screens or touch-operated controls, an input method shall be provided that complies with 1194.23.k₁₋₄.

When biometric forms of identification are used, an alternative form of identification or activation, not requiring users to possess particular biological characteristics, shall be provided.

Passwords can be used as an acceptable alternative to a biometric for of user id or control. This alternative must comply with the provisions of 1194. Artificial limbs or eyes may be unsuitable for biometric tests that rely on fingerprint or retinal scans.

**Requirement
 (b.1)**

See 1194.23.k₁₋₄

**Requirement
 (b.2)**

Fingerprinting may not be suitable for mobility impaired users; alternatives must be provided.

<i>Supported By</i>	Dragon Mobility
<i>Recommended Evaluation Criteria</i>	Provide alternatives for fingerprinting identification techniques.
<i>Testing Method</i>	Test alternative identification for electronic access.

**Requirement
 (b.3)**

Retinal scans may not be suitable for blind users as positioning may be critical; alternatives must be provided.

<i>Supported By</i>	JAWS
<i>Recommended Evaluation Criteria</i>	Provide alternative identification capabilities besides retinal scans.
<i>Testing Method</i>	Test alternative identification for electronic access.

Continued on next page

Section 1194.26.b, Continued

**Requirement
(b.4)**

If feedback is provided upon (un)successful for identification, this information must also be in an accessible format.

<i>Supported By</i>	JAWS
	MAGic
	Dragon
<i>Recommended Evaluation Criteria</i>	Unsuccessful identification must be provided in an accessible format.
<i>Testing Method</i>	Test for auditory or visual means of producing unsuccessful identification.

Section 1194.26.c

Standard 1194.26.c **Where provided, at least one of each type of expansion slots, ports, and connectors shall comply with publicly available industry standards.**

Requirement (c.1) **Proprietary slots, ports, and connectors must not be used.**

<i>Supported By</i>	JAWS
	MAGic
	Dragon
<i>Recommended Evaluation Criteria</i>	Proprietary slots, ports, and connectors must not be used.
<i>Testing Method</i>	Check for non-standard slots, ports, and connectors presenting connectivity issues with AT.

Requirement (c.2) **AT must interoperate with connectors and therefore any EIT device must use industry standard serial and parallel ports, USB 1.1 and 2.0 ports, PCMCIA (PC Card) slots, video/DVI ports, AGP, and wireless connectivity.**

<i>Supported By</i>	JAWS
	MAGic
	Dragon
<i>Recommended Evaluation Criteria</i>	All AT must be interoperable with any slots, ports, or connectors on desktop workstations and notebooks.
<i>Testing Method</i>	Check for non-standard slots, ports, and connectors presenting connectivity issues with AT.

Section 1194.26 End

Functional Recommended Evaluation Criteria

Section 1194.31

Standard 1194.31.a At least one mode of operation and information retrieval that does not require user vision shall be provided, or support for Assistive Technology, used by people who are blind or visually impaired, shall be provided.

Requirement (a.1) JAWS scripts can be supplied for software applications where the requirement cannot be met within that application.

<i>Supported By</i>	JAWS
<i>Recommended Evaluation Criteria</i>	Scripting must enhance accessibility of the performance of the screen reader.
<i>Testing Method</i>	Use JAWS scripts to see if non-speaking fields now speak, and whether focus is better and keystrokes have been added.

Requirement (a.2) Speech can be provided inherent to a hardware device where there is no computer based user interface.

<i>Supported By</i>	JAWS
<i>Recommended Evaluation Criteria</i>	Speech output is used for hardware devices to impart information unavailable through tactile labels or other alternatives.
<i>Testing Method</i>	Operate a hardware device to any auditory indicators for error messages, toggle controls, or any other informational speech provided.

Requirement (a.3) Braille or tactile labels can be supplied to provide additional information for buttons or other controls on hardware devices.

<i>Supported By</i>	JAWS
<i>Recommended Evaluation Criteria</i>	Braille and/or tactile labels provided to supplement visual labels.
<i>Testing Method</i>	Test tactile labels for correct operation and Braille labels for validity.

Continued on next page

Section 1194.31, Continued

Requirement
(a.4)

Software alternatives can be provided for digital displays.

<i>Supported By</i>	JAWS
<i>Recommended Evaluation Criteria</i>	Software alternatives for digital displays must provide equivalent information so that the device is usable in a productive manner.
<i>Testing Method</i>	<ul style="list-style-type: none">• Test software applications available functionality from the hardware is available through software.• Ensure software used complies with requirements of web based and/or software based applications.

Section 1194.31.b

Standard 1194.31.b At least one mode of operation and information retrieval that does not require visual acuity greater than 20/70 shall be provided in audio and enlarged print output working together or independently, or support for Assistive Technology used by people who are visually impaired shall be provided.

Requirement (b.1) **MAGic scripts can be supplied for software applications where the requirements cannot be met within that application.**

<i>Supported By</i>	MAGic
<i>Recommended Evaluation Criteria</i>	Add MAGic scripts to enhance software accessibility.
<i>Testing Method</i>	Test the application with MAGic scripts to see if there is better focus, additional keyboard access and better overall performance.

Requirement (b.2) **Tactile informational labels and/or large print labels can be supplied to enhance buttons and other controls on hardware devices.**

<i>Supported By</i>	JAWS
	MAGic
	Dragon
<i>Recommended Evaluation Criteria</i>	Provide alternatives to device labels to increase readability.
<i>Testing Method</i>	Look at labels to see if enhancements are needed and if so, do tactile or large print labels to provide better accessibility.

Requirement (b.3) **Increased font sizes and contrast controls can be provided for digital windows on hardware devices.**

<i>Supported By</i>	JAWS
	MAGic
	Dragon
<i>Recommended Evaluation Criteria</i>	Provide user selectable font sizes and contrast control for digital displays on hardware or provide software alternatives.
<i>Testing Method</i>	Test for display parameters to adjust font size, colors, and contrast. If not available, test for software alternatives.

Section 1194.31.c

**Standard
1194.31.c**

At least one mode of operation and information retrieval that does not require user hearing shall be provided, or support for Assistive Technology used by people who are deaf or hard of hearing shall be provided.

**Requirement
(c.1)**

Any auditory tones or speech must have textual equivalents for both software applications and hardware.

<i>Supported By</i>	Dragon
	Deaf/Hard of Hearing
<i>Recommended Evaluation Criteria</i>	Any auditory tones or speech must have textual equivalents for both software applications and hardware.
<i>Testing Method</i>	Test for text alternatives for auditory tones or speech in the hardware or provided as a software alternative.

Section 1194.31.d

**Standard
1194.31.d**

Where audio information is important for the use of a product, at least one mode of operation and information retrieval shall be provided in an enhanced auditory fashion, or support for assistive hearing devices shall be provided.

**Requirement
(d.1)**

Enhanced audio or support for assistive hearing can include, but is not limited to, such features as interactive voice response through TTY devices, transcription services, amplified sound, captioning, etc.

<i>Supported By</i>	Dragon
	Deaf/Hard of Hearing
<i>Recommended Evaluation Criteria</i>	Enhanced auditory capabilities must be provided when audio information is important for the use of a product.
<i>Testing Method</i>	Test for audio enhancements or alternatives to audio information.

Section 1194.31.e

**Standard
1194.31.e**

At least one mode of operation and information retrieval that does not require user speech shall be provided, or support for Assistive Technology used by people with disabilities shall be provided.

**Requirement
(e.1)**

Keyboard or alternative input for speech must be provided.

<i>Supported By</i>	Dragon
	Mobility
<i>Recommended Evaluation Criteria</i>	A speech alternative must be provided that can include, but not be limited to, keyboard access.
<i>Testing Method</i>	Test for speech alternatives using the keyboard, head mouse, mouth sticks, or any other alternative input to speech.

Section 1194.31.f

Standard 1194.31.f At least one mode of operation and information retrieval that does not require fine motor control or simultaneous actions and that is operable with limited reach and strength shall be provided.

Requirement (f.1) All hardware devices must contain controls, switches, buttons, etc. that are operable without fine motor control.

<i>Supported By</i>	Dragon
	Mobility
<i>Recommended Evaluation Criteria</i>	All controls, switches, buttons, etc. must be controllable without the use of fine motor skills or an alternative provided.
<i>Testing Method</i>	Test for alternative means of accessing controls, switches, etc that can be alternative devices or software equivalents.

Requirement (f.2) All hardware devices must contain controls, switches, buttons, etc. that are operable with limited reach and strength.

<i>Supported By</i>	Dragon
	Mobility
<i>Recommended Evaluation Criteria</i>	Provide alternatives to hardware that require specific reach limitations.
<i>Testing Method</i>	Test for hardware or software alternatives to reach limitations.

Section 1194.31 End

Information Documentation and Support

Section 1194.41

Standard 1194.41.a Product support documentation provided to end-users shall be made available in alternate formats upon request, at no additional charge.

Requirement (a.1) Documentation must be in one or more of the following formats: MS Word, RTF, properly tagged¹¹ PDF or HTML.

¹¹ Properly tagged means that the document is structured and can be accessibility checked using Adobe Acrobat's Accessibility full checker.

<i>Supported By</i>	JAWS
	MAGic
	Dragon
<i>Recommended Evaluation Criteria</i>	Documentation must convey all information in an accessible and productive manner necessary to understanding the product's functionality.
<i>Testing Method</i>	Navigate through the documentation using the AT to determine whether an explanation of the use of the product is understandable.

Requirement (a.2)

Any images, graphics, and/or screen shots must have equivalent text descriptions.

<i>Supported By</i>	JAWS
	MAGic
<i>Recommended Evaluation Criteria</i>	Any images, graphics, and/or screen shots must have equivalent text descriptions.
<i>Testing Method</i>	Be able to focus on equivalent text and ensure that the test describes the graphic in a comparable manner.

Continued on next page

Section 1194.41, Continued

**Requirement
(a.3)**

If documentation is in an interactive format that includes navigation with frames and table of contents, navigation must follow the standards set forth in 1194.21 and 1194.22, Software and Web Requirements.

<i>Supported By</i>	JAWS
	MAGic
	Dragon
<i>Recommended Evaluation Criteria</i>	Users must be able to navigate through interactive documentation in a productive manner using keyboard access, focus and navigation capabilities required in the Web and Software Requirements
<i>Testing Method</i>	Navigate through documentation in a logical productive manner using the keyboard to understand all necessary information.

**General
Guidelines**

The following are some general guidelines for providing documentation in an accessible format. MS Word and RTF documents share the following requirements:

1. For any image, graphic, chart, etc. provide a reference to the image and then describe the image dependent upon its content necessary for understanding.
 2. It is recommended that the generation of a Table of Contents have keyboard navigation capabilities.
 3. It is recommended that links be kept to a minimum; any link names should be meaningful and difficult, at best, to access with the keyboard.
-

Section 1194.41.b

**Standard
1194.41.b**

End-users shall have access to a description of the accessibility and compatibility features of products in alternate formats or alternate methods upon request, at no additional charge.

**Requirement
(b.1)**

All accessibility features of the documentation must be available electronically and meet the requirements specified in 1194.41(a).

<i>Supported By</i>	JAWS
	MAGic
	Dragon
<i>Recommended Evaluation Criteria</i>	Any accessibility features of the product must be documented and available in accessible electronic formats.
<i>Testing Method</i>	Note instructions for added keystrokes, navigation, JAWS scripting and other accessibility guides and test for accuracy.

Section 1194.41.c

Standard
1194.41.c

Support services for products shall accommodate the communication needs of end-users with disabilities.

Requirement
(c.1)

Support services must include alternative means of communications to include but not limited to TTY support, online chat capability, and e-mail support with 24-hour or less response time.

<i>Supported By</i>	JAWS
	MAGic
	Dragon
	Deaf/Hard of Hearing
<i>Recommended Evaluation Criteria</i>	Support services must address the communications needs of people with disabilities.
<i>Testing Method</i>	Test for TTY, e-mail, and chat capabilities, ensuring all these alternative means are compliant with web and software based requirements as well as telecommunication standards.

Section 1194.41 End

SSA's Additional Accessibility Requirements

In addition to meeting the Section 508 EIT Standards, SSA has developed a number of accessibility requirements that must be met in order to ensure that the hardware/software procured is compatible with the Assistive Technologies that are used by our employees with disabilities.

1.1 Software Compatibility with Assistive Technology

All IT software deliverables provided as part of the contractor's solution must be compatible with:

- JAWS screen reading software (Version 10);
- MAGic screen magnification software (Version 11); and
- Dragon Naturally Speaking Professional voice recognition software (Version 10).

"Software" includes, but is not limited to, any of the following which contain a user interface: websites, interactive web based applications, client server applications, desktop applications, mainframe applications, applets, middleware, and drivers.

"Compatible" means that the software shall fully conform to the applicable Section 508 standards when used with the assistive technology referenced above. Alternative assistive technologies embedded within the software to achieve accessibility (i.e. screen reader, screen magnifier, voice recognition) shall not be accepted as a substitute for compatibility with SSA's assistive technology environment.

If the contractor's solution includes installing the product in the SSA environment, the contractor shall explicitly state that the software shall be installed in a manner that shall not reduce the level of conformance with SSA accessibility requirements that currently exists.

For a complete description on the JAWS and MAGIC software packages, please refer to Freedom Scientific's web site at www.FreedomScientific.com. To obtain a 30/60 day version of the JAWS/MAGic software for development and testing, please send contact information and the SSA procurement number (for verification) to Charles Madsen at: cmadsen@FreedomScientific.com.

For a complete description on the Dragon Naturally Speaking software package, please refer to Nuance's web site at <http://www.nuance.com/naturallyspeaking>. To obtain a trial version of the Dragon Naturally Speaking software for development and testing, please send contact information and the SSA procurement number (for verification) to Tom Derrico at: tderrico@nuance.com.

1.2 Documentation in Accessible Formats

Any form of documentation provided (i.e. training manual, user guides, embedded documents etc.), including any documentation deliverables required in the statement of work, shall be provided in a fully accessible format.

The documents shall be provided in one of the following formats: Text, RTF, Microsoft Word or HTML format, or properly "tagged" PDF,. Properly tagged PDF's can be verified by using Adobe Acrobat's Accessibility Checker.

Documentation delivered in a manner that is interactive (e.g., table of contents, Index, Search, etc.) shall be keyboard navigable, move focus to selected items (or have a keyboard alternative) and be comparable in keyboard access to mouse usage. All images (especially screenshots and technical diagrams (which are the sole means for conveying instructions) should include alternative text explaining the image so that a person who is blind would understand the screenshot, chart, figure, etc. Documentation shall include information on the accessibility features of the product. If keyboard shortcuts are provided to allow access to program functionality, a list of the keyboard shortcuts shall be provided.

Documentation that is delivered in a video or multimedia publication shall comply with the Section 508 requirements detailed in 36 CFR part 1194.24 and the functional performance criteria detailed in 36 CFR 1194 Subpart C. In addition, SSA requires conformance to SSA's Accessibility Requirements for all video and multi-media deliverables. SSA does not accept text equivalents used to replace speech, and requires captions to be synchronized with speech.

1.3 Video and Sound Card Compatibility with Assistive Technology

Video and sound cards purchased separately for, or included with, any desktop or portable computer systems shall be compatible with the following Assistive Technologies:

- JAWS screen reading software (Version 10);
- MAGic screen magnification software (Version 11); and
- Dragon Naturally Speaking Professional voice recognition software (Version 10).

Compatibility shall be determined based on the video/and or sound card's ability to function with all three assistive technology in a manner that does not degrade either the core functionality of the AT or the performance of the AT.

For a listing of video and sound cards that are compatible with the JAWS and MAGic software packages, please refer to Freedom Scientific's web site at www.freedomscientific.com.

For a listing of video and sound cards that are compatible with Dragon Naturally Speaking Professional, please refer to Nuance's web site at www.nuance.com/naturallyspeaking.

1.4 Hardware Devices that Contain Digital Windows

- Any hardware device shall provide an audible response for information displayed in a visual only format (i.e. digital message window) either through software or firmware.
- Any hardware digital window that has the capability to magnify text shall do so for all screens either through software or firmware.
- Any hardware digital window that has the capability to adjust contrast settings shall provide a range of contrast levels either through software or firmware.
- Any hardware digital window that has the capability to be tilted for better viewing angles shall provide a range of settings.

If digital windows meet the above requirements through software residing on a computer workstation, the software must be "compatible" with

- JAWS screen reading software (Version 10);
- MAGic screen magnification software (Version 11); and
- Dragon Naturally Speaking Professional voice recognition software (Version 10).

Compatibility shall be determined based on the video/and or sound card's ability to function with all three assistive technology in a manner that does not degrade either the core functionality of the AT or the performance of the AT.

1.5 Technical Support and Assistance (Hotline)

Any technical support, help desks, or other support services provided to SSA shall accommodate the communication needs of end users with disabilities, and shall be provided in one or both of the following options. If both options are provided, each must conform to the accessibility requirements.

A toll-free telephone number that is accessible to all Government help desk personnel. This shall include the availability of TTY access for help desk personnel who may require assistance for the hearing-impaired. When this option is provided, it must be available during SSA working hours (i.e. between 6am Eastern and 6pm Pacific time).

- A toll-free telephone number that is accessible to all Government help desk personnel. This shall include the availability of TTY access for help desk personnel who may require assistance for the hearing-impaired. When this option is provided, it must be available during SSA working hours (i.e. between 6am Eastern and 6pm Pacific time).
- An internet-based web page that is accessible to all Government help desk personnel. This web site shall meet all of the requirements of Section 508 1194.22.

1.6 Training

All training materials provided to SSA must be in an accessible format. In addition, training materials on the use of the accessibility features of a product or service shall be provided.

1.7 Installation, Configuration & Integration Services

If the contractor provides installation, configuration and integration services for commercial EIT solutions or EIT solutions previously developed for other government entities, the contractor shall not install, configure or integrate the EIT solution in a way that reduces the existing EIT solution's level of conformance with SSA's accessibility requirements at the time the contract is awarded.

1.8 Maintenance & Replacements

Any updates or replacements to EIT products provided to SSA pursuant to this contract shall be fully accessible with all applicable SSA's accessibility requirements as described above. At a minimum, any updates or replacements to any IT deliverables shall not result in a decrease in accessibility from the EIT solution being maintained or replaced.

1.9 Labor Hours

If the anticipated labor hour deliverable is expected to involve tasks that relate to or require the use of E&IT, delivered labor hours shall include knowledge and capabilities necessary to conform to SSA's Accessibility Requirements.

1.10 Equivalent Facilitation

When a deliverable does not directly conform to the SSA Accessibility Requirements, but provides substantially equivalent or greater access by meeting the functional performance criteria in Subpart C of the Section 508 Standards, per Section 1194.31, then it is said to have provided Equivalent Facilitation.

Any approach providing Equivalent Facilitation that serves as a replacement to the Assistive Technologies SSA employs (e.g. an external speech engine) shall NOT be considered as an acceptable approach to Equivalent Facilitation. For any approach meeting Section 508 Standards using Equivalent Facilitation, the contractor shall be held accountable for maintaining and updating the approach.

Appendix A: Keystrokes

The following is a list of commonly used Windows and Internet Explorer (IE) keystrokes. The important issues to note is that application keystrokes must not conflict with reserved Windows and/or IE keystrokes and navigation must follow standard Windows navigation and selection standards. Most conflicts would occur with using the ALT key plus a keystroke so the IE and Netscape combinations must be avoided. There are usually not conflicts with the Assistive Technology keystrokes as these have special modifier keys and also have pass through keys.

Again, the important keyboard usage functionality that is inherent in windows needs to be retained in the applications. For example navigating to frames or panes should be with F6. Opening list boxes should be with ALT + Down Arrow or F4. This is true for software applications and browser applications including both Sun and Oracle based Java applets. A user typically does not know what kind of application they are in and expect to use keystrokes that they are familiar with.

Windows Keystrokes	
OBJECTIVE	METHOD
Set focus on a notification	Windows Key+B
View properties for the selected item	ALT+ENTER
Open the next menu to the left, or close a submenu	LEFT ARROW
Collapse current selection if it's expanded, or select parent folder	LEFT ARROW
Display the items in the active list in a dialog box	F4
Refresh the active window	F5
Cycle through screen elements in a window or on the desktop	F6
Display the top of the active window	HOME
Switch MouseKeys on and off	Left ALT +left SHIFT +NUM LOCK
Switch High Contrast on and off	Left ALT +left SHIFT +PRINT SCREEN
Open the next menu to the left, or close a submenu	LEFT ARROW
Collapse current selection if it's expanded, or select parent folder	LEFT ARROW
Display the items in the active list in a dialog box	F4
Refresh the active window	F5
Cycle through screen elements in a window or on the desktop	F6
Display the top of the active window	HOME
Collapse current selection if it's expanded, or select parent folder	LEFT ARROW
Display the shortcut menu for the selected item	Menu key
Switch ToggleKeys on and off	NUM LOCK for five seconds
Display all subfolders under the selected folder	NUM LOCK+ASTERISK on numeric keypad (*)
Collapse the selected folder	NUM LOCK+MINUS SIGN on numeric keypad (-)
Display the contents of the selected folder	NUM LOCK+PLUS SIGN on numeric keypad (+)
Open the next menu to the right, or open a submenu	RIGHT ARROW
Display current selection if it's collapsed, or select first subfolder	RIGHT ARROW

Windows Keystrokes	
OBJECTIVE	METHOD
Switch FilterKeys on and off	Right SHIFT for eight seconds
Display the items in the active list in a dialog box	F4
Refresh the active window	F5
Cycle through screen elements in a window or on the desktop	F6
Display the top of the active window	HOME
Switch MouseKeys on and off	Left ALT +left SHIFT +NUM LOCK
Switch High Contrast on and off	Left ALT +left SHIFT +PRINT SCREEN
Open the next menu to the left, or close a submenu	LEFT ARROW
Collapse current selection if it's expanded, or select parent folder	LEFT ARROW
Display the shortcut menu for the selected item	Menu key
Switch ToggleKeys on and off	NUM LOCK for five seconds
Display all subfolders under the selected folder	NUM LOCK+ASTERISK on numeric keypad (*)
Collapse the selected folder	NUM LOCK+MINUS SIGN on numeric keypad (-)
Display the contents of the selected folder	NUM LOCK+PLUS SIGN on numeric keypad (+)
Open the next menu to the right, or open a submenu	RIGHT ARROW
Display current selection if it's collapsed, or select first subfolder	RIGHT ARROW
Switch FilterKeys on and off	Right SHIFT for eight seconds
Switch StickyKeys on and off	SHIFT five times
Prevent the CD from automatically playing	SHIFT when you insert a CD into the CD-ROM drive
Select more than one item in a window or on the desktop, or select text within a document	SHIFT with any of the arrow keys
Delete selected item permanently without placing the item in the Recycle Bin	SHIFT+DELETE
Display the shortcut menu for the selected item	SHIFT+F10
Move backward through options in a dialog box	SHIFT+TAB
Select or clear the check box if the active option is a check box in a dialog box	SPACEBAR
Move forward through options in a dialog box	TAB
Carry out the corresponding command	Underlined letter in a command name on an open menu
Display or hide the Start menu	Windows Key
Lock your computer if you are connected to a network domain, or switch users if you are not connected to a network domain	Windows Key+ L
Display the System Properties dialog box	Windows Key+BREAK
Show the desktop	Windows Key+D
Open My Computer	Windows Key+E
Search for a file or folder	Windows Key+F
Display Windows Help	Windows Key+F1
Minimize all windows	Windows Key+M
Open the Run dialog box	Windows Key+R
Restores minimized windows	Windows Key+Shift+M

Windows Keystrokes	
OBJECTIVE	METHOD
Opens Utility Manager	Windows Key+U
Displays the properties of the selected object	ALT+Enter
Cycle through items in the order they were opened	ALT+ESC
Close the active item, or quit the active program	ALT+F4
Opens the shortcut menu for the active window	ALT+SPACEBAR
Display the System menu for the active window	ALT+SPACEBAR
Switch between open items	ALT+TAB
Carry out the corresponding command or select the corresponding option in a dialog box	ALT+Underlined letter
Display the corresponding menu	ALT+Underlined letter in a menu name
Select a button if the active option is a group of option buttons in a dialog box	Arrow keys
View the folder one level up in My Computer or Windows Explorer	BACKSPACE
Open a folder one level up if a folder is selected in the Save As or Open dialog box in a dialog box.	BACKSPACE
Copy selected item	CTRL while dragging an item
Select all	CTRL+A
Copy	CTRL+C
Move the insertion point to the beginning of the next paragraph	CTRL+DOWN ARROW
Display the Start menu	CTRL+ESC
Close the active document in programs that allow you to have multiple documents open simultaneously	CTRL+F4
Move the insertion point to the beginning of the previous word	CTRL+LEFT ARROW
Move the insertion point to the beginning of the next word	CTRL+RIGHT ARROW
Create shortcut to selected item	CTRL+SHIFT while dragging an item
Highlight a block of text	CTRL+SHIFT with any of the arrow keys
Move backward through tabs in a dialog box	CTRL+SHIFT+TAB
Move forward through tabs in a dialog box	CTRL+TAB
Move the insertion point to the beginning of the previous paragraph	CTRL+UP ARROW
Paste	CTRL+V
Search for computers	CTRL+Windows Key+F
Cut	CTRL+X
Undo	CTRL+Z
Delete	DELETE
Display the bottom of the active window	END
Carry out the command for the active option or button in a dialog box	ENTER
Cancel the current task	ESC
Display Help in a dialog box	F1
Activate the menu bar in the active program	F10
Rename selected item	F2
Search for a file or folder	F3
Display the Address bar list in My Computer or Windows Explorer	F4
Display the items in the active list in a dialog box	F4

Windows Keystrokes

OBJECTIVE	METHOD
Refresh the active window.	F5
Cycle through screen elements in a window or on the desktop	F6
Display the top of the active window	HOME
Switch MouseKeys on and off	Left ALT +left SHIFT +NUM LOCK
Switch High Contrast on and off	Left ALT +left SHIFT +PRINT SCREEN

Internet Explorer

OBJECTIVE	METHOD
Insert the contents of the Clipboard at the selected location	CTRL+V
Activate a selected link	ENTER
Add "www." to the beginning and ".com" to the end of the text typed in the Address bar	CTRL+ENTER
Add the current page to your favorites	CTRL+D
Change paper, headers and footers, orientation, and margins for this page	ALT+U
Close Print Preview	ALT+C
Close the current window	CTRL+W
Copy the selected items to the Clipboard	CTRL+C
Display a list of addresses you've typed	F4
Display a list of zoom percentages	ALT+Z
Display a shortcut menu for a link	SHIFT+F10
Display Internet Explorer Help, or when in a dialog box, display context Help on an item.	F1
Display the first page to be printed	ALT+HOME
Display the last page to be printed	ALT+END
Display the next page to be printed	ALT+RIGHT ARROW
Display the previous page to be printed	ALT+LEFT ARROW
Find on this page	CTRL+F
Go to a new location	CTRL+O or CTRL+L
Go to the next page	ALT+RIGHT ARROW
Go to the previous page	ALT+LEFT ARROW or BACKSPACE
Go to your Home page	ALT+HOME
In the History or Favorites bars, open multiple folders	CTRL+click
Move back between frames	SHIFT+CTRL+TAB or SHIFT + F6
Move back through the items on a Web page, the Address bar, and the Links bar.	SHIFT+TAB
Move back through the list of AutoComplete matches	DOWN ARROW
Move forward between frames	CTRL+TAB or F6
Move forward through the items on a Web page, the Address bar, and the Links bar	TAB

Internet Explorer	
OBJECTIVE	METHOD
Move forward through the list of AutoComplete matches	UP ARROW
Move selected item down in the Favorites list in the Organize Favorites dialog box	ALT+DOWN ARROW
Move selected item up in the Favorites list in the Organize Favorites dialog box	ALT+UP ARROW
Move to the beginning of a document	HOME
Move to the end of a document	END
Open a new window	CTRL+N
Open the Favorites bar	CTRL+I
Open the History bar	CTRL+H
Open the Organize Favorites dialog box	CTRL+B
Open the Search bar	CTRL+E
Print the current page or active frame	CTRL+P
Refresh the current Web page, even if the time stamp for the Web version and your locally stored version are the same	CTRL+F5
Refresh the current Web page	F5 or CTRL+R
Remove the selected items and copy them to the Clipboard	CTRL+X
Save the current page	CTRL+S
Scroll toward the beginning of a document in larger increments	PAGE UP
Scroll toward the beginning of a document	UP ARROW
Scroll toward the end of a document in larger increments	PAGE DOWN
Scroll toward the end of a document	DOWN ARROW
Select all items on the current Web page	CTRL+A
Select the text in the Address bar	ALT+D
Set printing options and print the page	ALT+P
Specify how you want frames to print. This option is available only if you are printing a Web page that uses frames	ALT+F
Stop downloading a page	ESC
Toggle between full-screen and regular views of the browser window	F11
Type the number of the page you want displayed	ALT+A
When in the Address bar, move the cursor left to the next logical break in the address (period or slash)	CTRL+LEFT ARROW
When in the Address bar, move the cursor right to the next logical break in the address (period or slash)	CTRL+RIGHT ARROW
Zoom in	ALT+PLUS
Zoom out	ALT+MINUS

General Navigation and Selection	
OBJECTIVE	METHOD
Navigate through radio buttons	Arrow key
Select a radio button	Space bar or arrow key
Navigate through check boxes	TAB
Select check boxes	SPACE BAR
Select contiguous items in a list box	SHIFT + Arrow key
Select non-contiguous items in a list box	Shift + F8 and Up or Down Arrow key and then space bar to select or re-select the item